

Federal Court



Cour fédérale

Date: 20161117

**Dockets: T-1741-08
T-1946-09**

Citation: 2016 FC 1279

Ottawa, Ontario, November 17, 2016

PRESENT: The Honourable Mr. Justice Manson

BETWEEN:

**EXCALIBRE OIL TOOLS LTD, EXCALIBRE
DOWNHOLE TOOLS LTD, KUDU
INDUSTRIES INC, CARDER INVESTMENTS
LP, CARDER MANAGEMENT LTD AND
LOGAN COMPLETION SYSTEMS INC**

Plaintiffs

and

**ADVANTAGE PRODUCTS INC, LYNNE P.
TESSIER, JAMES L. WEBER AND JOHN P.
DOYLE**

Defendants

Docket: T-1946-09

AND BETWEEN:

**ADVANTAGE PRODUCTS INC, LYNNE P.
TESSIER, JAMES L. WEBER AND JOHN P.
DOYLE**

Plaintiffs

and

**EXCALIBRE OIL TOOLS LTD, EXCALIBRE
DOWNHOLE TOOLS LTD, KUDU
INDUSTRIES INC, CARDER INVESTMENTS
LP, CARDER MANAGEMENT LTD AND
LOGAN COMPLETION SYSTEMS INC**

Defendants

JUDGMENT AND REASONS

Table of contents

I.	The Pleadings	4
II.	Summary of Results in these Actions.....	8
	A. Ownership of the Patents	8
	B. The '467 Patent.....	9
	C. The '734 Patent.....	9
	D. The '026 Patent.....	9
	E. Section 7(a) of the Trade-marks Act	9
	F. Remedies.....	9
III.	The Parties	10
	A. Background	10
	B. The Technology	15
	(1) Oil Production	15
	(2) Torque Anchors.....	17
IV.	The API Patents.....	18
	A. Canadian Patent No. 2,264,467 (the '467, or Jaw Patent).....	18
	B. Canadian Patent No. 2,373,734 (the '734, or Spring Patent)	21
	C. Canadian Patent No. 2,386,026 (the '026, or Stop Patent)	22
V.	API Fact Witness Evidence	24
	A. Lynn Tessier	24

B.	John Doyle.....	27
C.	Kerry Van Metre.....	27
D.	Kelly McGowan	28
E.	Jack Bootsman	29
VI.	Excalibre Fact Witness Evidence.....	30
A.	Michael Burton	30
B.	Colin Aldridge.....	31
C.	Kevin Kelm	32
D.	Edward Moore	33
E.	Dan Echino	35
F.	James Esposito	36
G.	Leanne Wichmann Cohen	37
H.	Lisa Redhead	38
VII.	API Expert Witness, Dr. Robert Sorem.....	40
VIII.	Excalibre Expert Witnesses	41
A.	Dr. Wooley	41
B.	Mr. Skoczylas	45
IX.	Claim Construction.....	46
A.	Relevant Dates	46
B.	The Person Skilled in the Art (POSITA).....	48
C.	Common General Knowledge	49
	(1) Relevant dates for considering common general knowledge as it relates to anticipation and obviousness – the claim date (priority documents)	49
	(2) Common General Knowledge	50
	(3) Prior Art.....	52
D.	Claim Terms Needing Construction	54
	(1) Tubular	54
	(2) Housing	55
	(3) Casing-engaging wall.....	59
	(4) “First Stop” and “Second Stop”	61
X.	Ownership of the API Patents.....	64
XI.	The Tests of the TorqStopper™ Torque Anchors	64

A.	Excalibre Parties testing at the C-FER Laboratories on July 30, 2014 and July 31, 2014	65
B.	Testing at the API Facilities on January 12, 2015	68
C.	Demonstrative Testing at C-FER on January 13, 2015	70
XII.	The Law – Principles of Utility, Anticipation, Obviousness, and Infringement.....	71
A.	Utility.....	71
B.	Anticipation.....	72
C.	Obviousness	73
D.	Infringement	75
XIII.	The ‘467 Patent.....	77
A.	Utility.....	77
B.	Infringement	81
XIV.	The ‘734 Patent.....	85
A.	Anticipation – ‘843 Burton Patent	85
B.	Anticipation – Prior Use	86
C.	Obviousness	86
XV.	The ‘026 Patent.....	91
A.	Utility.....	91
B.	Anticipation.....	94
C.	Obviousness	94
D.	Infringement	96
XVI.	Section 7(a) of the <i>Trade-marks Act</i>	99
XVII.	Remedies.....	105
XVIII.	Costs.....	105

I. The Pleadings

[1] Two actions are brought before the Court concerning the validity and/or infringement of a number of claims in three Canadian Patents, which are owned by Lynn Tessier (“Tessier”), James Weber (“Weber”), and John Doyle (“Doyle”): Canadian Patent No. 2,264,467 (the “467

Patent”); Canadian Patent No. 2,373,734 (the “734 Patent”); and Canadian Patent No. 2,386,026 (the “026 Patent”) (collectively, the “API Patents”).

[2] The plaintiffs in the patent impeachment action (T-1741-08), who are the defendants in the infringement action (T-1946-09), are the companies Excalibre Oil Tools Ltd. (“Excalibre Oil”), Excalibre Downhole Tools Ltd. (“Excalibre Downhole”), Kudu Industries Inc. (“Kudu”), Carder Investments LP and Carder Management Ltd. (together, “Carder”), and Logan Completion Systems Inc. (“Logan”) (collectively, the “Excalibre Parties”).

[3] The defendants in the patent impeachment action, and plaintiffs in the patent infringement action, are the companies Advantage Products Inc. (“API”) and MSI Machineering Solutions Inc. (“MSI Offshore”) , and the individuals Weber, Tessier, and Doyle (collectively, the “API Parties”). Former defendant to the patent impeachment action, and co-plaintiff in the patent infringement action, is the former company MSI Machineering Solutions Inc. (“MSI Alberta”).

[4] In the first action, the Excalibre Parties assert that each of the API Patents is invalid: the ‘467 Patent because of inutility; the ‘734 Patent because of anticipation or obviousness; and the ‘026 Patent because of anticipation, obviousness and because claim 1 fails to recite a means to actuate the jaw and is, therefore, broader than the invention made and is inoperable. There is also a claim under section 7(a) of the *Trade-marks Act*, RSC, 1985, c T-13, wherein the Excalibre Parties assert that the API Parties damaged the Excalibre Parties’ business relations through false and misleading statements.

[5] In the second action, the API Parties against the Excalibre Parties assert that various versions of a torque anchor sold by the Excalibre Parties (the “CTA Torque Anchor”) infringe the API Patents.

[6] The API Patents all relate to a torque anchor tool designed to prevent the rotation of a rotary pump stator (or downhole tool) that is part of a Progressing Cavity Pump system (“PC Pump”) designed to extract oil from subterranean reservoirs (the “TorqStopperTM” torque anchors).

[7] The following issues are raised in the two actions:

1. Ownership of the ‘467 and ‘026 Patents
 - a. What is the legal effect of the assignments relating to the ‘467 and ‘026 Patents?
2. Patent Infringement and Validity
 - a. The ‘467 Patent:
 - b. What is the proper construction of claims 1 to 17 of the ‘467 Patent?
 - c. Is the tool recited in claims 1 to 17 of the ‘467 Patent inoperable and lacking utility, in that each of claims 1 to 17 fails to recite an essential and necessary feature for the tool to operate, namely:
 - i. each of claims 1 to 17 fails to recite a spring to bias the jaw outwardly?; and
 - ii. each of claims 1 to 17 is inoperable or lacks utility in that each of the claims fails to recite a stop to limit rotation or movement of the jaw?
 - d. Do any of the versions of the CTA Torque Anchor (i.e., versions 1 to 6, and the offset version) infringe claims 1 to 9 and 12 to 17 of the ‘467 Patent?

e. If infringed, who of the Excalibre Parties is liable for infringement of the asserted claims of the '467 Patent?

b. The '734 Patent:

f. Are claims 1 to 19 anticipated by US Patent 4,739,834 (the "'843 Burton Patent")?

g. Are claims 1 to 19 obvious in view of US Patent 4,699,224 (the "'224 Burton Patent"); the '843 Burton Patent; US Patent 6,037,693 (the "'693 Aldridge Patent); and/or the '467 Patent and prior public use(s) of tools embodying the '467 patented invention?

c. The '026 Patent:

h. Is claim 1 broader than the invention made, inoperable and lacking utility, in that claim 1 fails to recite the essential and necessary feature for the tool to operate, namely that the jaw be outwardly biased by means of a spring?

i. Are claims 1 to 7 anticipated by the '843 Burton Patent?

j. Are claims 1 to 7 obvious in view of the '224 Burton Patent, the '834 Burton Patent, the '693 Aldridge Patent, and/or the '467 Patent and prior public use(s) of tools embodying the '467 patented invention?

k. Do any of the versions of the CTA Torque Anchor (i.e., versions 1 to 6, and the offset version) infringe claims 1 or 2 of the '026 Patent?

l. If infringed, which of the versions and models of the CTA Torque Anchor infringe either claim 1 or 2?

m. If infringed, who of the Excalibre Parties is liable for infringement of claim 1 or 2 of the '026 Patent?

d. False and Misleading Statements

n. Did API or MSI Offshore through their solicitor make false and misleading statements, in letters referenced at paragraphs 25 to 27 of the Further Amended Statement of Claim in Court File No. T-1741-08, which tended to discredit the business goods or services of the Excalibre Parties, contrary to subsection 7(a) of the *Trade-marks Act*?

e. Remedies

o. Are the API Parties entitled to injunctive relief, declaratory relief, an Order for the delivery up of infringing products, and/or an election of profits from the Excalibre Parties?

p. Are the Excalibre Parties entitled to a permanent injunction restraining each of the API Parties from making representations to third parties, including customers and potential customers of the Excalibre Parties, that any of the Excalibre Parties' CTA Torque Anchors infringe the claims of the API Patents?

q. Are the Excalibre Parties entitled to declaratory relief against the API Parties?

II. Summary of Results in these Actions

A. *Ownership of the Patents*

[8] The API Patents were validly assigned to Weber, Tessier, and Doyle.

B. *The '467 Patent*

[9] The claims of the '467 Patent are valid; however, none of asserted claims 1 to 9 or 12 to 17 are infringed by any version of the CTA Torque Anchors.

C. *The '734 Patent*

[10] The '734 Patent is invalid because claims 1 to 19 are obvious.

D. *The '026 Patent*

[11] Claim 1 of the '026 Patent is invalid for inutility, because claim 1 is broader than any invention made or disclosed, and lacks utility. Claims 2 to 7 are valid; however, neither asserted claim 1 nor claim 2 is infringed by any version of the CTA Torque Anchors.

E. *Section 7(a) of the Trade-marks Act*

[12] API made false or misleading statements tending to discredit the business, goods, or services of the Excalibre Parties, which caused damage to the business of the Excalibre Parties, contrary to section 7(a) of the *Trade-marks Act*.

F. *Remedies*

[13] Given the findings on validity and infringement, the API Parties are not entitled to any of the relief sought. The Excalibre Parties are entitled to damages against API resulting from the

misleading statements made, pursuant to section 7(a) of the *Trade-marks Act*, which are to be determined in a reference after trial.

III. The Parties

A. *Background*

[14] Excalibre Oil was an Alberta-incorporated company, who in the past distributed and sold CTA Torque Anchors (CTA stands for “Centralized Torque Anchor”). These CTA Torque Anchors were manufactured by the company Tebo Industries Ltd. (“Tebo”). Both Excalibre Oil and Tebo have been struck from the Alberta Corporate Register: Excalibre Oil on August 7, 2009; and Tebo on May 2, 2012. Presently, the business of both companies is being carried on by Excalibre Downhole.

[15] Excalibre Downhole is a company incorporated in Alberta, with an office at 5007-23 Avenue, S.E., Calgary, Alberta. From 2009 to 2012, Excalibre Downhole sold the CTA Torque Anchors manufactured by Tebo. Excalibre Downhole currently manufactures and sells, among other products, these CTA Torque Anchors.

[16] Kudu is a company incorporated in Alberta that manufactures and supplies artificial lift technologies, including PC Pumps. Since July 2007, Kudu has purchased CTA Torque Anchors from Excalibre Oil and, later, Excalibre Downhole, and sold them to the oil well servicing and operating industry.

[17] Carder Investments LP, formerly known as Tanroc Equipment LP, is a registered limited partnership in Alberta. Carder Management Ltd., formerly known as Tanroc Management Ltd., is a corporation incorporated in Alberta, which was at all material times the general partner of Carder Investments LP. Carder is in the business of selling downhole products to the oil well servicing and operating industry, particularly in Western Canada. Since July 2007, Carder has purchased CTA Torque Anchors from Excalibre Oil and, later, Excalibre Downhole, and sold these devices to the oil well servicing and operating industry.

[18] Logan, formerly known as Source Energy Tool Services Inc., is a company incorporated in Alberta that is in the business of selling downhole products to the oil well servicing and operating industry, particularly in Western Canada. In February 2011, Source Energy Tool Services Inc. amalgamated with Complete Oil Tools Inc., and began operating under the name Logan. Since July 2007, Logan has purchased CTA Torque Anchors from Excalibre Oil and, later, Excalibre Downhole, and sold these devices to the oil well servicing and operating industry.

[19] API is, and was at all material times, an existing company incorporated in Alberta. API designs and manufactures oilfield tools, including tools designed for PC Pumps. API sells torque anchors, in competition with the CTA Torque Anchor, under the trademark TorqStopperTM. API is, and has been at all material times, the Canadian licensee of the API Patents. From December 31, 2002 to January 16, 2014, API held a sublicense to the API Patents from MSI Alberta, who was the licensee of MSI Offshore. Since January 16, 2014, API has been licensed to make, use,

and sell the subject matter of the API Patents, pursuant to a license granted by the current owners Weber, Tessier, and Doyle.

[20] Weber is listed owner of the API Patents and is, and was at all material times, a director and officer of API.

[21] Tessier is listed owner of the API Patents and is, and was at all material times, a director and a shareholder of API.

[22] Doyle is listed owner of the API Patents. Doyle was at one time an employee and part of management at API.

[23] MSI Alberta was a company incorporated in Alberta. It was struck from the Alberta Corporate Register on June 7, 2013. MSI Offshore is a company incorporated under the laws of the Turks and Caicos, a British Overseas Territory in the Caribbean, having a registered office c/o the Hallmark Trust Company, Tropicana Plaza, Leeward Hwy, P.O. Box 656, Providenciales, Turks and Caicos, British West Indies. Prior to January 16, 2014, when MSI Offshore assigned the API Patents to Weber, Tessier, and Doyle, MSI Offshore was recorded by the CIPO as the owner of the API Patents.

[24] The Excalibre Parties manufacture and/or sell CTA Torque Anchors. In July 2007, Tebo created Interim CTA Torque Anchor versions 1A and 1B. Excalibre Oil sold Interim CTA Torque Anchors from July 2007 to approximately April 2008. In or about April 2008, Excalibre

Downhole created CTA Torque Anchors which were available in versions 2A, 2B, 3, 4, 5, and 6.

Excalibre Downhole also created a single “offset” version of the CTA Torque Anchor, at the request of Kudu, for a specific Kudu customer (the “offset CTA Torque Anchor”).

[25] The different versions of the CTA Torque Anchor can be described as follows:

- Interim CTA Torque Anchor version 1A – a torque anchor with a tubular housing, having a single moveable slip and two rigid slips, spaced equidistant around the housing, and possessing “milled out” portions on both side of the moveable slip and a pad for stopping over-rotation of the moveable slip.
- Interim CTA Torque Anchor version 1B – a torque anchor similar to Interim CTA Torque Anchor version 1A, but possessing a pair of moveable slips placed vertically one above the other along a longitudinal axis of the torque anchor.
- CTA Torque Anchor version 2A – a torque anchor with a tubular housing, having a single moveable slip and two rigid slips, spaced equidistant around the housing, and possessing a singled “milled out” portion on one side of the moveable slip. The unmilled side of the moveable slip prevents over-rotation.
- CTA Torque Anchor version 2B – a torque anchor similar to CTA Torque Anchor version 2A, but possessing a pair of moveable slips placed vertically one above the other along a longitudinal axis of the torque anchor.
- Offset CTA Torque Anchor – a modified version 2A torque anchor, wherein the rigid slips are shorter than the moveable slip, causing the torque anchor to be decentralized in the casing.
- CTA Torque Anchor version 3 – a torque anchor with a tubular housing, having a single moveable slip and two rigid slips, spaced equidistant around the housing, where the moveable slip is mounted upon a mount block, which prevents the over-rotation of the moveable slip.
- CTA Torque Anchor version 4 – a torque anchor similar to CTA Torque Anchor version 3, but where the rigid slips include multiple holes such that the slips can be attached at different depths in the tool housing.

- CTA Torque Anchor version 5 – a torque anchor similar to CTA Torque Anchor version 4, but where the recesses for the rigid slips include steps to afford deeper threads for increased fastening strength.
- CTA Torque Anchor version 6 – a torque anchor similar to CTA Torque Anchor version 5, but where the moveable jaw has three teeth, rather than two.

[26] API has manufactured and sold different models of the TorqStopperTM torque anchors: the “T” series model, since on or about April 1999, which is an embodiment of the ‘467 Patent; the TS model, since on or about March 2000; the TN model, since on or about June 2001, which has an internal torsional spring and is an embodiment of the ‘734 Patent; and the TX model, since on or about March 2002, which has a stop feature and is an embodiment of the ‘026 Patent.

[27] In or about September 2006, Tebo (now Excalibre Downhole) created a single prototype torque anchor (the “Prototype”). On September 14, 2006, a third party distributor, Terra Alta, displayed the Prototype at the 13th Heavy Oil Symposium in Lloydminster Alberta. Although, the Prototype was never sold, it came to the attention of the API Parties.

[28] From July 2007 to about April 2008, Excalibre Oil and Excalibre Downhole sold approximately 320 Interim CTA Torque Anchors to Kudu, Tanroc (now Carder), and Source (now Logan). These Interim CTA Torque Anchors were then sold to various oil well completion companies in Western Canada, including Husky Energy Inc. (“Husky”) and Bronco Energy Inc. (“Bronco”).

[29] Between January and May of 2008, a number of customers and former customers of Kudu, Tanroc (now Carder), and Source (now Logan), including Husky and Bronco, received letters from Mr. Sean Goodwin (the “Goodwin Letters”), an Alberta lawyer representing API and MSI Offshore. In the letters, Goodwin expressly stated that “API holds three Canadian patents for anti-rotation tools implementing one jaw”; “API holds the first patent position in the world for single jaw anti-rotation tools which utilize a pivoting jaw for engaging the casing, jamming the tool against the casing and preventing rotation of the tool and equipment secured thereto”; and that API is the “sole authorized source [in Canada] of single jaw torque anchors utilizing a single jaw projecting from the tool's circumference”. Further, Goodwin alleged that should such customers purchase CTA Torque Anchors, they would be infringing API’s patent rights.

B. *The Technology*

[30] The Excalibre Parties and the API Parties provided an agreed joint technical and background summary for understanding the API Patents, containing information which the parties submit would have been known by a person of ordinary skill in the art (“POSITA”) at the relevant times.

(1) Oil Production

[31] Oil wells are borings into the subterranean reservoir that are designed to bring oil hydrocarbons to the surface, which often have a metal bore/casing, referred to as the wellbore casing, or casing, inside which production tubing moves the produced oil to the surface. If a

reservoir lacks the pressure to force the oil to the surface, a pumping mechanism is deployed.

One example of a pump used to produce oil is a PC Pump.

[32] A PC Pump consists of a helical rotor that turns within a double helix channel formed in an elastomeric stator, which is bound inside a steel tube. In an oil well application, a PC Pump is located deep down at the bottom of the well (“downhole”), and is attached to a drive unit mounted on a frame at the surface. The drive unit rotates a polished shaft, which is connected to a series of linked rods (the “rod string”) that extend downhole and drive the PC Pump.

[33] The PC Pump is a positive displacement pump. The rotor is coupled to and driven by the bottom of the rod string. A tube surrounds the rod string (the “tubing string”), and as the rotor is rotated, oil is pushed up through the PC Pump and tubing string to the surface of the well. At the surface, the tubing string is capped and sealed, and the oil is directed down a flowline.

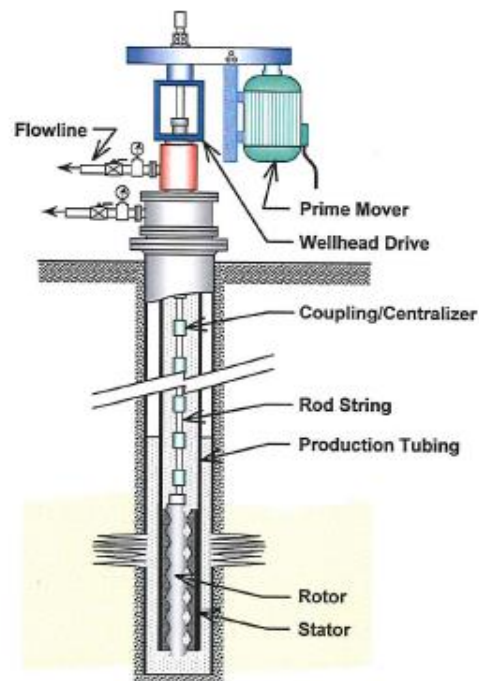

Standard PC Pump System

(2) Torque Anchors

[34] Most PC Pump systems operate such that the rotor turns in a clockwise direction. This rotation can cause vibration and reactive torque. The reactive torque (i.e., friction) in the system can cause the production tubing connections to become unthreaded. This can result in the loss of the PC Pump or the tubing string into the reservoir.

[35] Torque anchors (also known as anti-rotation devices or “no-turn” tools) are frequently used in PC Pump systems to prevent the unscrewing of the tubing string above the PC Pump. When a torque anchor is attached to the tubing string, above or below the PC Pump, the reactive torque that the PC Pump imparts on the production tubing is neutralized, and transferred to the wellbore casing, which is cemented within the wellbore. A torque anchor thereby prevents the pump stator and the tubing string from rotating in a counter-clockwise direction when the PC Pump is actuated, which prevents the unscrewing of the tubing string above the PC Pump.

[36] Both Parties agree that examples of prior art in the field of torque anchors include, but are not limited to, the torque anchors disclosed in: (1) Canadian Patent No. 1,274,470 (the “470 Patent”), which uses a cam-actuation system to actuate movable cam slips into a casing-engaging position; and (2) U.S. Patent No. 5,275,239 (the “239 Patent”, an embodiment of which is the “Obrejanu Tool”), which uses the rotation of an anchoring member to cause movable anchoring members to bite into the well casing, locking against further rotation.

IV. The API Patents

A. *Canadian Patent No. 2,264,467 (the '467, or Jaw Patent)*

[37] The filing date for the '467 Patent is March 5, 1999. It was published on September 5, 2000, and issued on February 26, 2002. The '467 Patent was invented by Tessier.

[38] A statement of the invention is set out on page 2 of the '467 Patent specification:

A simplified anti-rotation tool is provided, having only one moving part but which both prevents rotation and stabilizes that to which it is connected. In simplistic terms, the tool connects to a PC Pump or other downhole tool and upon rotation in one direction, causes a jaw to pivot radially outwardly from the tool housing to engage the casing wall and to arrest tool rotation. This action causes the tool housing to move oppositely and come to rest against the casing opposing the jaw. The tool housing and the downhole tool are thereby restrained and stabilized by the casing wall.

In a broad apparatus aspect, an anti-rotation tool comprises: a tubular housing having a bore and having at least one end for connection to a downhole tool and a jaw having a hinge and a radial tip, the jaw being pivoted at its hinge from one side of the housing, the jaw's pivot being offset from the jaw's center of gravity so that the jaw is pivotable upon rotation of the tool between a first position stowed against the housing for permitting movement within the casing, and a second position wherein the radial tip swings outwardly from the housing to engage the casing for arresting tool rotation and forcing the housing against the casing opposite the jaw.

[...]

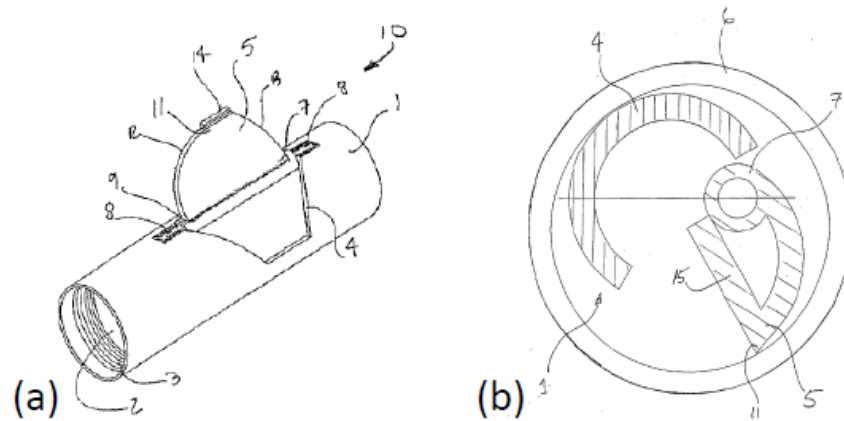

Figure 2. (a) Figure 1(a) of the '467 Patent, schematic of the preferred embodiment of the '467 Patent—(1) housing, (2) bore, (5) jaw, (7) jaw's hinge edge, and (11) radial tip of jaw; (b) Figure 3(a) of the '467 Patent, cross-section view of the preferred embodiment of the '467 Patent in the casing-engaging position—same numbering as Figure 1(a) where (6) indicates the casing of the well bore.

[39] The three independent claims are claims 1, 8, and 16:

- Claim 1:

A tool to prevent rotation of a downhole tool suspended in a wellbore casing comprising:

- a. a tubular housing having a wall for engaging the casing and having at least one end for connection to the downhole tool; and
- b. a jaw having a radial tip and which is pivoted from a point on the housing opposing the casing-engaging wall for varying the effective diameter of the tool, the jaw's pivot being offset from the jaw's center of gravity so that the jaw is pivotable upon rotation of the tool between
 - i. a first position stowed against the housing for minimizing the tool's effective diameter and permitting movement within the casing, and
 - ii. a second casing-engaging position wherein the radial tip pivots outwardly from the housing to increase the tool's effective diameter so that both the radial tip and the housing wall engage the casing for arresting tool rotation.

• Claim 8:

A tool to prevent rotation of a downhole tool suspended in a wellbore casing comprising:

- a. a tubular housing having a wall for engaging the casing and having at least one end for connection to the downhole tool; and
- b. a jaw having a hinge and a radial tip, the jaw being pivoted at its hinge from one side of the housing, the jaw's pivot being offset from the jaw's center of gravity so that the jaw is pivotable upon rotation of the tool between a first position stowed against the housing for permitting movement within the casing, and a second position wherein the radial tip swings outwardly from the housing to engage the casing for arresting tool rotation and forcing the housing against the casing opposite the jaw, the jaw having a profile and the tubular housing having a corresponding profile so that when stowed, the jaw only projects minimally from the housing, the jaw further being trapezoidal in shape having sloped top and bottom edges so that the jaw is caused to rotate to the stowed position if contacted with an obstruction in the wellbore during running in and tripping out.

• Claim 16:

A tool for stabilizing a downhole tool suspended in a wellbore casing comprising:

- a. a tubular housing having a wall for engaging the casing and having at least one end for connection to the downhole tool; and
- b. a jaw having a radial tip and which is pivoted from a point on the housing opposing the casing-engaging wall for varying the effective diameter of the tool, the jaw's pivot being offset from the jaw's center of gravity so that the jaw is pivotable upon rotation of the tool between
 - i. a first position stowed against the housing for minimizing the tool's effective diameter and permitting movement within the casing, and
 - ii. a second casing-engaging position wherein the radial tip pivots outwardly from the housing to increase the tool's effective diameter so that both the radial tip and the housing wall engage the casing, wherein the engagement of

housing wall and the casing stabilizes the tool and the downhole tool.

B. *Canadian Patent No. 2,373,734 (the '734, or Spring Patent)*

[40] The Canadian filing date for the '734 Patent is February 28, 2002. It has a US priority date of September 26, 2001. The '734 Patent was published on March 26, 2003, and issued on December 20, 2005. The '734 Patent was invented, and is currently owned, by Weber, Tessier, and Doyle.

[41] A statement of the invention is set out on page 2 of the '734 Patent specification. The general description of the tool is substantially the same as that of the '467 Patent specification, but with the following differences:

[...]

The jaw is pivoted at its hinge from one side of the housing, so that the jaw is biased so as to pivot outwardly to a first casing-engaging position, wherein the radial tip engages the casing, and the housing is urged against the casing opposite the jaw. The jaw is also inwardly pivotable to a second compressed position towards the housing to enable movement within the casing during tripping in and tripping out.

Preferably, the jaw is biased to the casing-engaging position by a torsional member extending through the hinge, which is rigidly connected to the housing at a first end and to the jaw at a second end. Compression of the jaw twists the torsional member into torsion which then acts to bias or urge the jaw outwardly again.

[...]

[42] There are two independent claims, claims 1 and 16:

- Claim 1:

A tool to prevent rotation of a downhole tool suspended in a wellbore casing comprising:

- a tubular housing having a wall for engaging the casing and having at least one end for connection to the downhole tool;
- a jaw having a radial tip and which is rotatable along an axis along a wall of the housing opposing the casing-engaging wall for varying the effective diameter of the tool; and
- a spring, acting between the jaw and the housing so as to bias the jaw outwardly to a first casing-engaging position wherein the radial tip is positioned outwardly from the housing to increase the tool's effective diameter so that the radial tip engages the casing and the housing wall engages the casing for arresting tool rotation and further, to permit a second compressed position wherein the jaw is temporarily compressed towards the housing for minimizing the tool's effective diameter and permitting movement within the casing.

• Claim 16

An improvement to a tool used to prevent rotation of a downhole tool suspended in a wellbore casing, the tool having a housing and at least one jaw having an edge which is pivotable at a hinge on the housing, the hinge having first and second ends pivotally connected to the housing, the improvement comprising:

- a torsional member having first and second ends;
- a first holder for pinning the first end of the torsional member to the housing; and
- a second holder pivotable with the jaw and for pinning the second end of the torsional member to the jaw so that when the jaw pivots towards the housing, the torsional member is twisted for biasing the jaw outwardly.

C. *Canadian Patent No. 2,386,026 (the '026, or Stop Patent)*

[43] The Canadian filing date for the '026 Patent is May 13, 2002. It has a US priority date of September 26, 2001. The '026 Patent was published on March 26, 2003, and issued on January 16, 2007. The '734 Patent was invented, and is currently owned, by Weber, Tessier, and Doyle.

[44] A statement of the invention is set out on page 2 of the '026 Patent specification. The general description of the tool is substantially the same as the statement of the invention in the '467 Patent specification and the '734 Patent specification, but with the following differences:

[...]

Preferably, overextension of the jaw during assembly is prevented using cooperating stops in the jaw and the housing. In a broad aspect, a downhole tool comprises a tubular housing for suspension in a wellbore casing and having a wall which engages the wellbore casing and having at least one end for threaded connection to the downhole tool, a jaw having a radial tip and which is rotatable along an axis along a base of the jaw and along a hinge on the wall of the housing opposing the casing-engaging wall for varying the effective diameter of the tool, a first stop formed on the base of the jaw, and a second stop formed in the wall of the housing at the hinge. The first and second stops cooperate so as to limit maximum rotation of the jaw, while permitting the effective diameter of the tool to increase to a diameter greater than the casing.

[45] Independent claim 1 provides:

- Claim 1:

A downhole tool suspended in a wellbore casing comprising:

- a tubular housing for suspension in a wellbore casing and having a wall which engages the wellbore casing and having at least one end for threaded connection to the downhole tool;
- a jaw having a radial tip and which is rotatable along an axis along a base of the jaw and along a hinge on wall of the housing opposing the casing-engaging wall for varying the effective diameter of the tool;
- a first stop formed on the base of the jaw; and
- a second stop formed in the wall of the housing at the hinge, the first and second stops cooperating so as to limit maximum rotation of the jaw and to permit the effective diameter of the tool to increase to a diameter greater than the casing.

V. API Fact Witness Evidence

A. *Lynn Tessier*

[46] Lynn Tessier has a Bachelor of Applied Science in Mechanical Engineering, and a Master of Applied Science in Mechanical Engineering, both from the University of Waterloo. He is a Registered Professional Engineer, and a fellow of the Canadian Academy of Engineers. Between 1998 and 2002, Tessier was an Engineering Advisor for SKF Magnetic Bearings Inc. and was directly involved in the development of the API Patents. Currently, and at all material times, Tessier is/was a shareholder, director, and consultant for API.

[47] Tessier gave evidence that he was approached by Weber to design a torque anchor that was robust, simple to use and easy to manufacture. He also testified that the tool invented, the ‘467 TorqStopperTM torque anchor, was the “ultimate” in simplicity. Three versions of the ‘467 torque anchors were created by November 1999: (1) a ‘467 TorqStopperTM torque anchor with open bore; (2) a ‘467 TorqStopperTM torque anchor with closed-bore, which could be run above the PC Pump; and (3) a ‘467 TorqStopperTM torque anchor with horizontally oriented, banded extensions protruding from the opposite side the housing from the jaw, to enable the tool to be used with an oversized pump.

[48] By November 2000, Weber, Tessier, and Doyle (together, the “Inventors”) were designing, manufacturing, and selling versions of the ‘467 TorqStopperTM torque anchor with external, coiled springs added to bias the jaw. This spring was incorporated to help actuate the door of the closed-bore ‘467 TorqStopperTM torque anchor. The closed-bore necessitated that the

door could not be milled from the body of the tool; therefore, it was lighter and did not set consistently downhole. In heavy oil, particularly, there would be “stiction” between the door and the housing of the tool, which would lead to difficulty getting the door open. Tessier admitted that the early TorqStopper™ torque anchors that incorporated the spring feature were retrofitted ‘467 torque anchors with coiled springs. He further testified that the Inventors subsequently moved to make the ‘734 torque anchors, which had an internal torsional member (also called a torsional spring), in order to protect the spring from acidic production fluids in the oil well.

[49] Tessier also stated that the Inventors were getting reports that the doors of both the ‘467 and the ‘734 TorqStopper™ torque anchors were prone to being damaged by the rough treatment of the tools by rig operators, who were assembling the TorqStopper™ torque anchors onto the production tubing. Rig operators often used the doors as a lever to thread the torque anchor onto the PC Pump or the production tubing up-hole, which would damage the door and could potentially result in the rig operator ripping the door from the housing. The evidence is that the Inventors of the ‘026 Patent solved this issue by adding a notch feature, called a “stop”, which made the door more robust by transferring the torquing force to the housing.

[50] Counsel for the Excalibre Parties objected to Tessier testifying to the development of the patented tools, that is, the evolution of the TorqStopper™ torque anchors from the ‘467 TorqStopper™ torque anchors to the ‘026 TorqStopper™ torque anchors. After hearing submissions from the parties on this point, I decided that this evidence could be a factor when considering the question of obviousness (*Sanofi-Synthelabo Canada Inc v Apotex Inc*, 2008 SCC 61 at para 70 [*Sanofi*]) as stated by Mr. Justice Rothstein:

Another important factor [regarding obviousness] may arise from considering the actual course of conduct which culminated in the making of the invention. It is true that obviousness is largely concerned with how a skilled worker would have acted in light of the prior art. But this is no reason to exclude evidence on the history of the invention, particularly where the knowledge of those involved in finding the invention is no lower than would be expected of the skilled person.

[51] Tessier further stated that API touts the fact that the TorqStopperTM torque anchor decentralizes the downhole tool as a benefit of using the TorqStopperTM torque anchor, because it causes the tool to be pressed against the casing, which increases overall stability. He stated that it is his view that stability is a function of the overall length of contact (i.e. the contact between the casing, and the side of the TorqStopperTM torque anchor and the attached downhole tool).

[52] Finally, Tessier, in his capacity as a director of API, testified that Goodwin had been authorized by API to send the Goodwin Letters, which form the basis of the Excalibre Parties' section 7(a) claim. He confirmed that API and MSI Offshore had directed Goodwin to send the following letters:

- a. a letter to Kudu explicitly stating that the CTA Torque Anchor infringed the API Patents (the "January 18, 2008 Kudu Letter");
- b. a letter notifying Husky that single jawed torque anchors infringed the API Patents and advising Husky to determine the extent of their liability (the "January 16, 2008 Husky Letter");
- c. a letter advising Husky that API had been credibly informed that Husky was planning to source CTA Torque Anchors and warning them to review their exposure under Canadian patent laws (the "February 1, 2008 Husky Letter");

- d. a letter advising Husky that they would be included in the present infringement action if they did not stop sourcing CTA Torque Anchors immediately (the “April 28, 2008 Husky Letter”); and
- e. a letter advising Bronco that they would be included in the present infringement action if they did not stop purchasing CTA Torque Anchors immediately (the “May 16, 2008 Bronco Letter”).

B. *John Doyle*

[53] John Doyle is the Vice President, Manufacturing at General Magnetic International Inc. Doyle is a Master Machinist who originally trained at Sir James Farmer Norton & Co. Ltd. From 1998 to 2001, Doyle was employed by SKF/Revolve Mechanical Bearing as a mechanical designer/technologist. From 2001 to 2010, he was the Chief Designer/General Manager at API.

[54] Doyle testified that the Inventors tested a number of different ideas for the “stop” used in the ‘026 TorqStopperTM torque anchor before settling on the notches that are shown in figure 12(a) of the ‘026 Patent.

C. *Kerry Van Metre*

[55] Kerry Van Metre is the Chief Operating Officer of Royal Well Servicing Ltd. In 2002, he was self-employed as a contractor to Petrovera Resources Limited, and in the business of servicing oil rigs. He testified that he had personally set many TorqStopperTM torque anchors and other torque anchors.

[56] Van Metre testified that he had never had any difficulty setting the open bore '467 TorqStopper™ torque anchor. Additionally, he testified that the setting protocol used in the API Tests (discussed below) was representative of the protocol that would be used on an oil rig, and that the protocol used in the 2014 C-FER Tests (discussed below) resulted in a turning speed that was slower than a typical turning speed used in the field. On cross-examination, Van Metre testified that generally the TorqStopper™ torque anchors used on the rigs, with which he was familiar, would set easily by turning the production tubing with a “fairly good snap”, but that sometimes you would have to make more than one attempt to ensure that the torque anchor set. I found him to be a credible witness.

D. *Kelly McGowan*

[57] Kelly McGowan is the owner of Trilogy Oilfield Ltd., a company that rents oilfield tools and services oil wells in British Columbia, Alberta, and Saskatchewan. McGowan is a shareholder in API, and Trilogy has been in a business relationship with API since 2001, as a distributor of TorqStopper™ torque anchors.

[58] McGowan testified that he first saw a '467 TorqStopper™ torque anchor in 1999 while he was working for Magen Oil and Gas Tools, and that the first commercial sale of which he is aware occurred on October 7, 1999. He testified that he had observed Weber set a '467 TorqStopper™ torque anchor at a Wascana Energy Inc. oil rig, and that he remembers the '467 TorqStopper™ torque anchor setting within a half-turn. Additionally, McGowan testified that the protocol used at the API Tests was representative of a “normal” setting procedure, and that the turning speed used at the 2014 C-FER Tests was “gentle”, not “oil patch”.

[59] On cross-examination, McGowan stated that he first became aware of API and the TorqStopper™ torque anchor because it was proposed to him as a business opportunity, and that he was promoting the sale of the TorqStopper™ torque anchor as early as August 5, 1999. Again, I found McGowan to be a credible witness.

E. *Jack Bootsman*

[60] Jack Bootsman is the owner of Jack Bootsman Supervision Ltd., a consulting company that troubleshoots oil production problems, particularly problems with heavy oil and PC Pump production. Between 1999 and 2004, he was a Well Servicing Superintendent with Petrovera Resources Limited. Bootsman testified that he had witnessed TorqStopper™ torque anchors being set at Petrovera wells, and that the setting procedure was to rotate the up-hole tube hanger to the right with a pipe wrench. He stated that the setting procedure shown in the videos of the API Tests was “standard”.

[61] On cross-examination, Bootsman admitted that he did not start supervising rigs that used the TorqStopper™ torque anchor until after 2004, when he was consulting as a Wellsite Supervisor and the ‘734 TorqStopper™ torque anchor was the main version used by the industry. He was unfamiliar with the ‘467 TorqStopper™ torque anchor, and had no experience with how the ‘467 TorqStopper™ torque anchor would be set.

VI. Excalibre Fact Witness Evidence

A. *Michael Burton*

[62] Michael Burton is an engineer and entrepreneur. He is the inventor of the '224 and '834 Burton Patents. Burton has a B.Sc. and a M.Sc. in Aerospace from Princeton. In 1983, he switched from the aerospace industry into the oil and gas industry, where he specialized in directional drilling. From 1983 to 1985, he worked to develop the short radius directional tool whose two main embodiments are described by the '224 and '834 Burton Patents (the "Burton Tool").

[63] Burton stated that the Burton Tool functions by displacing the drilling string to one side in a borehole. This directs the drilling string upwards and enables the borehole drilling team to control the angle of the borehole. The body of the Burton Tool is a non-rotating eccentric tool with "fins" that fits around the drill and displaces it in the borehole. On cross-examination, Burton clarified that the tool does not inhibit the rotation of the drill string, nor does it stabilize the drill string.

[64] He testified that the fins of the Burton Tool are either flexible steel (the '224 embodiment of the Burton Tool) or rigid fins that pivot around a spring-loaded hinge (the '834 embodiment of the Burton Tool), and that these fins can engage with either the casing or the open borehole, depending on where the drill is set up. Additionally, the fins only operate in one direction because the design of the blade is such that its rotation is constrained by a "stop" where it butts up against the edge of the tool. This stop is also used to maintain each fin at the proper angle on the

tool. On cross-examination, Burton agreed that the stop does not function up-hole because of what it does, and how the tool is assembled.

[65] Burton's evidence is that the first commercial use of the Burton Tool was in Kansas in the winter of 1985/1986. He stated that the Amoco Corporation ("Amoco") asked to test the tool in 1988. In 1990, he sold the technology to an investment group from Switzerland, who sold it to Amoco. Amoco, in turn, licenses the technology out to various people in the oil well drilling industry.

[66] On cross-examination, Burton agreed that directional drilling was a still a fairly specialized field when he developed the Burton Tool, in 1985, and that the tools used in directional drilling were not used in other areas of oil well operations. He did not quantify the number of Burton Tools in operation in 2003; however, he testified that Amoco was advertising the Burton Tool to individuals in the drilling industry. Further, he explained that directional drilling has become ubiquitous, since 1985, such that almost all oil well drilling is directional today. Finally, he stated that all workers in the oil and gas industry have had "their hands on the wrenches", meaning that all of the rig operators know a lot about both drilling and production because they are involved in all steps in the process.

B. *Colin Aldridge*

[67] Colin Aldridge is the owner of Anglo Precision Machining Ltd., and the inventor of the '693 Aldridge Patent, which discloses a torque anchor tool (the "Aldridge Tool"). Aldridge

apprenticed in England as a machinist at the Atomic Energy Authority. After moving to Canada, he worked as a machinist at a number of companies, particularly Chriscor from 1993 to 1998.

[68] Aldridge testified that he designed the Aldridge Tool while at Chriscor, around 1995, because they lost the rights to continue manufacturing the torque anchor that they had been machining. He testified that the Aldridge Tool was a “scroll-lock” tool, wherein drag blocks located within a drag housing cause slips to set into the casing when the body of the tool was rotated. He also testified that these slips are set into slots, which act as “stops” on the rotation of the slips.

[69] On cross-examination, Aldridge clarified that the Aldridge Tool had a plurality of evenly spaced slips, and emphasized that he deliberately set about to create a tool that did not utilize springs, because he felt that springs were unreliable downhole due to the effects of wellbore fluids.

C. *Kevin Kelm*

[70] Kevin Kelm is the owner of Progressive Completions Ltd., a company that, among other things, sells, installs, and fishes out torque anchors from oil and gas wells. He has experience with many types of torque anchors, including the TorqStopperTM torque anchors and CTA Torque Anchors. He does not have a business relationship with either API or Excalibre.

[71] Kelm has personally fished out ‘467 TorqStopperTM torque anchors from oil wells, and it was his experience that customers did not particularly like the ‘467 TorqStopperTM torque

anchors because of reliability issues. His evidence was that the spring-loaded versions of the TorqStopper™ torque anchors were very popular.

D. *Edward Moore*

[72] Edward Moore is a tool technologist, and the owner of Excalibre Downhole. In 1990, he started Tebo, a company that subcontracted manufacturing for other companies.

[73] Moore testified that, while at Tebo, he saw the Obrejanu Tool and thought that he could come up with his own torque anchor. He testified that the first version that he and his team invented was a torque anchor known as the “Garay Tool”, which was first used in 1996. Moore testified that, by 1999, three thousand to four thousand Garay Tools had been built. These tools were sold directly to Husky, and pump companies in British Columbia, Alberta, and Saskatchewan (e.g., Kudu, Tanroc, and Weatherford International). Moore confirmed that the Garay Tool had been patented: Canadian Patent No. 2,159,659, filed October 2, 1995 and issued March 19, 2002 (the “Garay Patent”).

[74] Moore testified that he first saw a ‘467 TorqStopper™ torque anchor because one was sent to him by a member of his sales team, who thought that the ‘467 TorqStopper™ torque anchor infringed the Garay Patent. Representatives of API denied that any version of the TorqStopper™ torque anchor infringed the Garay Patent. His testimony was corroborated by a letter dated March 30, 2005, sent by Goodwin, on behalf of API, to Dennis Yasui at Brownlee LLP.

[75] Moore further gave evidence that his team developed the CTA Torque Anchor because of a conversation he had with operators at National Oilwell Varco, who indicated that they sometimes needed to run sensors downhole with the tools, and that the large mounting blocks, which held the spring-loaded slips on the Garay Tool, made this difficult. Further, he testified that he had noticed that, because of the design of the slips on the Garay Tool, when the Garay Tool was in a horizontal well, only one of the three slips would be engaged with the casing because of the weight of the tool and tubing. He stated that to solve these two issues, his team changed two of the mounting blocks with spring-loaded slips to rigid slips, keeping only one moving slip.

[76] Moore's evidence was that this change from spring-loaded slips on mounting blocks to rigid slips allowed him to keep the tool centralized. He stated that keeping the tool centralized was important to prevent issues that occur when the tool rests in sand in the wellbore, and to allow additional tubing, such as coil tubing for hot oil, to go down around the tool.

[77] Moore stated that one of the benefits of the CTA Torque Anchor was the fact that the rigid slips were removable and that the tool could be serviced up-hole. Further, the move to CTA Torque Anchor version 4, which has multiple holes on the rigid slips that allow for different slips to be used on different tool bodies, allowed the company to carry fewer inventories. He stated that this interchangeability allowed him to create the Offset CTA Torque Anchor for Kudu, who had a customer that needed to run large cables past the pump. Moore also stated that the change in the placement of the "stop" between the different versions was due to the fact he was always looking to improve the tool, not because he was trying to work around the '026 Patent.

[78] When asked about the Prototype tool, Moore indicated that this tool did not have rigid slips, and was not a version of the CTA Torque Anchor. He stated that only one tool was ever made, and that this tool was neither sold nor used in the field.

[79] Moore's evidence was that the Goodwin Letters had a serious and deleterious effect on the sales of the CTA Torque Anchor. He stated that he had seen a letter written by Goodwin to Husky and that both he and Ray Mills, one of the owners of Kudu, offered Husky an indemnity, but that this was ineffective in getting Husky to change its mind about purchasing the CTA Torque Anchor. He stated that he has continually made efforts to try to convince Husky to reconsider purchasing the CTA Torque Anchor, to no avail. However, on cross-examination he admitted that he did not keep any documentation of his offer of indemnity or efforts to persuade Husky or Bronco to continue purchasing the CTA Torque Anchor.

[80] Additionally, on cross-examination, Moore admitted that the sales of the CTA Torque Anchor to Kudu did not immediately halt after Kudu received the January 18, 2008 Kudu Letter. He admitted that the sales tapered off, and that the Excalibre Parties did not submit into evidence invoices from that period which would corroborate his testimony about how sales were affected. He further admitted that sales to Tanroc did not cease immediately upon their receipt of a similar letter from Goodwin.

E. *Dan Echino*

[81] Dan Echino is a businessman in the Calgary area who specializes in tools and equipment used in the oil and gas industry. From 1991 to 2004, he was the owner of Corlac Industries Ltd.

(“Corlac”), which was an early supplier of ‘467 TorqStopper™ torque anchors. Echino testified that there was a lot of skepticism about the ‘467 TorqStopper™ torque anchor when it first came on the market, and that they were slow to sell at first. His evidence was of little value to the issues before the Court.

F. *James Esposito*

[82] James Esposito is a Registered Professional Engineer. In 2008, he was the Chief Operating Officer at Bronco. Esposito testified that Bronco wells used PC Pumps and torque anchors, and that each well had a torque anchor downhole with a replacement in inventory. He testified that he was familiar with PC Pumps and torque anchors, but that it was his Vice-President of Production, Stephen Terry, who was in charge of day-to-day operations and well completions.

[83] Esposito testified that he remembered getting the May 16, 2008 Bronco Letter. Esposito stated that at first he thought that the letter was a joke. After realizing that the May 16, 2008 Bronco Letter was real, he discussed options with Terry and they decided that Bronco was going to stop using the CTA Torque Anchor immediately.

[84] Esposito testified that Bronco was particularly sensitive about their image in 2008, because they had just raised money from investors and were working in heavy oil on a First Nation’s Reserve, with a plan to drill 69 new wells. He stated that, because Bronco had so much going on, at the time, they could not afford interruptions in business or bad publicity and, therefore, they made the decision to quit buying CTA Torque Anchors. He testified that he told

Terry to cease purchasing the CTA Torque Anchor immediately, although they did not pull any of the installed CTA Torque Anchors from their operating wells.

[85] Neither he nor Terry wrote back to Goodwin. Further, he testified that he did not contact his corporate lawyers to get an infringement opinion, because he was loathe to spend the company's money on a legal opinion, if litigation could be avoided by changing their purchasing practices. He stated that he did not believe that Bronco was infringing, because they were not distributing CTA Torque Anchors, but he felt threatened and took steps to minimize the threat to the company.

G. *Leanne Wichmann Cohen*

[86] Leanne Wichmann Cohen is a lawyer, who was called to the Alberta Bar in 1998. In 2008, she was a member of the Husky legal department, and was the legal lead for the information technology and intellectual property departments. Wichmann Cohen testified in these actions under subpoena.

[87] Wichmann Cohen testified that, in 2008, Husky was very litigation averse and that its legal strategy was to take the easiest, most non-confrontational route, because the company did not want to spend any money on litigation. She recalled the January 16, 2008 Husky Letter, and the steps taken to investigate how this letter related to and impacted the operations of Husky wells. At the end of these investigations, she instructed Hector Munoz, who was in charge of purchasing in Lloydminster, to stop purchasing the CTA Torque Anchor and to source a comparable product.

[88] Wichmann Cohen's position was that Husky made no inquiries into whether the CTA Torque Anchor, in fact, infringed the API Patents because they had a "Plan B" in place, wherein they identified a comparable and clearly non-infringing product. Her goal at the time was to resolve the issue, and she needed neither an infringement opinion nor assistance from outside legal counsel to take steps that would lead to a resolution.

[89] Wichmann Cohen also remembered receiving the April 28, 2008 Husky Letter. After receiving this letter, she had Munoz confirm that his team was proceeding with her previous instructions to replace their CTA Torque Anchors. Wichmann Cohen stated that she understood these letters as a threat that they would be added to the litigation.

[90] Wichmann Cohen assured Goodwin that Husky had been removing the CTA Torque Anchors, and that Husky had been taking the appropriate steps to address the alleged infringement by use of CTA Torque Anchors. On cross-examination, she testified that she did not recall receiving documents from Moore or Excalibre, but that an offer of an indemnity would not have changed her mind because she did not want to enter into a situation where Husky would be vulnerable to litigation.

H. *Lisa Redhead*

[91] Lisa Redhead is a Registered Professional Engineer employed with Husky. From 2007 to 2008, she was a member of the District Projects Group for the Lloydminster District. Redhead testified that, as a member of the District Projects Group, she provided technical assistance to the

Procurement Group, and ensured that the Procurement Group was sourcing the most competitive products on the market to use in Husky's new well completions.

[92] Redhead stated that she was directly involved in testing the efficacy of the CTA Torque Anchor in Husky wells in August 2007, and in making the decision to switch Husky's Auto-Purchase Orders for the Lloydminster District to the CTA Torque Anchor in January 2008. Her team found the CTA Torque Anchor to be reliable, and that using the CTA Torque Anchor saved Husky \$150-500 per well. On cross-examination, Redhead stated that the District Projects Group had not tested other torque anchor products at the time to determine if they were better than the Excalibre CTA Torque Anchor.

[93] Redhead explained that all of the torque anchors used by Husky in 2007 and early 2008 were sourced from three pump companies: Kudu, Tanroc, and National Oilwell. Further, she had directed Howard Staniforth, a Husky Completions Coordinator, to source only Excalibre CTA Torque Anchors from Kudu and Tanroc, both of whom had been providing API TorqStopperTM torque anchors to Husky up to that time. She stated that National Oilwell was not a distributor of CTA Torque Anchors in 2007, and that the District Projects Group had not decided which torque anchor they would recommend the Procurement Group to source from National Oilwell.

[94] Redhead left the District Projects Group in February 2008. On cross-examination, she admitted that she did not know when the stop-purchase order for CTA Torque Anchors came down.

VII. API Expert Witness, Dr. Robert Sorem

[95] Dr. Robert Sorem received a B.Sc. in Mechanical Engineering in 1986, a M.Sc. in Mechanical Engineering in 1988, and a Ph.D. in Mechanical Engineering from the University of Kansas in 1991. He is a named co-inventor of at least 17 U.S. patents.

[96] Dr. Sorem is an Associate Professor of Mechanical Engineering at the University of Kansas School of Engineering. From 1991 to 1994, he was a development engineer for Dowell Schlumberger in Tulsa, Oklahoma and Huston, Texas. His industry experience encompasses the design, manufacturing, and testing of tubing inflatable packers and running tools for oilfield service. Since 1994, Dr. Sorem has held a tenured position in the Mechanical Engineering Department at the University of Kansas School of Engineering, where he teaches a wide variety of classes, including Introduction to Engineering and Machine Design, Mechanics of Materials, and Mechanics of Composite Materials.

[97] Dr. Sorem was qualified as an expert in mechanical engineering and downhole tools. However, his downhole tool experience is primarily with downhole packers and inflatable packers, and he has very limited practical experience with PC Pumps and torque anchors. On cross-examination, Dr. Sorem admitted that his first and only experience with torque anchors prior to these actions was during a previous litigation between API and Corlac in or around 2007, in which he was called as an expert witness for API.

[98] Dr. Sorem conducted the API Tests and provided two expert reports: one addressing the infringement of the '467 Patent and the '026 Patent; and the other addressing the validity of the '467 Patent, the '734 Patent, and the '026 Patent.

VIII. Excalibre Expert Witnesses

A. *Dr. Wooley*

[99] Dr. Gary R. Wooley received his B.Sc. in Mechanical Engineering, in 1969; his M.Sc. in Engineering Mechanics, in 1970; and his Ph.D. in Engineering Science from Louisiana State University, in 1972. He has testified as an expert witness in over 50 trials, in both Canada and the U.S.

[100] Dr. Wooley is the President of Wooley and Associates, Inc., an American company that offers engineering consulting to the petroleum industry. Prior to founding Wooley and Associates, Inc., in 1986, he worked for Shell Oil, Chevron Oil, Humble Oil (Exxon), Atlantic Richfield Co., and Enertech Engineering. He was also, briefly, an instructor at Louisiana State University.

[101] Dr. Wooley has been qualified as an expert in mechanical tools and tool design, particularly tools used in the oil and gas industry. Dr. Wooley conducted the 2014 C-FER Tests and provided a single expert report, focusing on the validity of the API Patents.

[102] At the beginning of his examination in chief, Dr. Wooley explained that there were a number of oversights and mistakes in his expert report. Counsel for the Excalibre Parties stated that these were merely clerical errors. Counsel for the API Parties objected to the admission of these corrections into evidence, arguing that they went beyond mere clerical errors and that their admission would cause substantial prejudice to the API Parties, particularly because they had already closed their case. In the alternative, counsel for the API Parties submitted that Dr. Wooley's testimony be given no weight.

[103] I agree with counsel for the API Parties that it was improper for Dr. Wooley to make significant corrections to his expert report during the trial. These corrections were not minor corrections; rather they were corrections of conceptual mistakes going to the heart of the opinion in the report. Some of the corrections changed the meaning of entire sections of the report. Even though Dr. Wooley could be cross-examined on these corrections, they would clearly prejudice the API Parties and there is no reasonable excuse for not having corrected these omissions or errors prior to trial.

[104] Counsel for the API Parties also objected to Dr. Wooley's testimony on claims 2 to 7 of the '026 Patent on the basis that there was no analysis of these claims set out in his expert report. Counsel for the Excalibre Parties submitted that this testimony was within Dr. Wooley's right to explain and amplify what was in his report.

[105] The scope of an expert's testimony, outside the four corners of his or her report, is an issue that has recently been considered by Madam Justice Wilson of the Ontario Superior Court

of Justice in *Moore v Getahun*, 2014 ONSC 237, affirmed in 2015 ONCA 55 [*Moore*]. In Ontario, the limits of expert testimony is governed by Rule 53.03(3) of the *Rules of Civil Procedure*, RRO 1990, Reg 194, which states:

An expert witness may not testify with respect to an issue, except with leave of the trial judge, unless the substance of his or her testimony with respect to that issue is set out in,

- (a) a report served under this rule; or
- (b) a supplementary report served on every other party to the action not less than 30 days before the commencement of the trial.

[106] Although there is no directly equivalent provision in the *Federal Courts Rules*, SOR/98-106, this Court accepts that Rules 280(1) and 280(1.1) are procedurally equivalent to Ontario Rule 53.03(3):

Tendering of expert's evidence at trial

280 (1) Unless the Court orders otherwise, evidence in chief of an expert witness may be tendered at trial by

- (a) the witness reading into evidence all or part of an affidavit or statement referred to in paragraph 279(b); and
- (b) the witness explaining any of the content of an affidavit or statement that has been read into evidence.

Other evidence with leave

(1.1) Despite subsection (1), an expert witness may tender other evidence in chief with leave of the Court.

Présentation à l'instruction

280 (1) Sauf ordonnance contraire de la Cour, la déposition d'un témoin expert dans le cadre d'un interrogatoire principal peut être présentée en preuve à l'instruction:

- a) par la lecture par celui-ci de tout ou partie de l'affidavit ou de la déclaration visé à l'alinéa 279b);
- b) par son témoignage expliquant tout passage de l'affidavit ou de la déclaration qu'il a lu.

Déposition avec autorisation

(1.1) Malgré le paragraphe (1), le témoin expert peut présenter toute autre déposition au cours de l'interrogatoire principal avec l'autorisation de la Cour.

[107] In *Moore*, above, Madam Justice Wilson applied the approach of the Ontario Court of Appeal in *Marchand (Litigation Guardian of) v Public General Hospital Society of Chatham* (2000), 51 OR (3d) 97, which articulated that an “expert may explain and amplify what is in his or her report but only on matters that are ‘latent in’ or ‘touched on’ by the report. An expert may not testify about matters that open up a new field not mentioned in the report” (see also, *Kilitzoglou v Cure*, 2012 ONSC 3411).

[108] The principle that an expert can proffer evidence that is touched on, but not explicitly discussed in, his or her report was applied by Mr. Justice François Lemieux in *Canada (Minister of Citizenship and Immigration) v Obodzinsky*, 2001 FCT 239.

[109] In the present case, Dr. Wooley did not discuss the obviousness of claims 2 to 7 of the ‘026 Patent in the version of his expert report that was filed with the Court. Further, his testimony neither expanded on a matter latent in his report, nor helped the Court understand statements in his report, because he erroneously concluded that finding that the independent claim of a patent was obvious would render the dependent claims obvious.

[110] Based upon the above, I give no weight to his evidence on the following issues:

- a. the validity of the dependent claims of the API Patents;
- b. the obviousness of the ‘467 Patent with regards to the Burton Tool; and
- c. the obviousness analysis of claims 2 to 7 of the ‘026 Patent.

B. *Mr. Skoczylas*

[111] Mr. Paul Skoczylas received a B.Sc. in Mechanical Engineering in 1996, and a M.Sc. in Mechanical Engineering in 2001, from the University of Alberta. He is a Registered Professional Engineer in the Province of Alberta and a member of the Association of Professional Engineers and Geoscientists of Alberta. He is a Manager of Engineering Services at C-FER Technologies, a subsidiary of Alberta Innovates – Technology Futures, which is a corporation that works closely with industry, academia, and the Province of Alberta to support research and innovation.

[112] He is an expert in PC Pump downhole applications, and has taught courses on PC Pump systems and the use of PC Pump software around the world. Currently, Skoczylas manages a multi-disciplinary group studying the reliability of both PC Pumps and Electrical Submersible Pumps. He has authored, individually or jointly, more than 14 articles dealing with various aspects of PC Pump applications.

[113] Skoczylas has been qualified as an expert in PC Pumps and PC Pump accessories. However, counsel for the API Parties raised the issue of the appropriate weight of his evidence, given his lack of practical experience on oil rigs. Skoczylas conducted the Demonstrative Tests and provided a single expert report focusing on the expert reports of both Dr. Sorem and Gregg Perkin (report not filed with the Court).

[114] Skoczylas testified that he was present at the 2014 C-FER Tests and, in his opinion, the procedures followed by Dr. Wooley were slow but not inappropriate, based upon his

understanding of the language of the claims of the '467 Patent and the physics of downhole tool interactions. Skoczylas stated that, in a vertical well, because rotation is applied at the surface, hundreds of meters away from the tool, it may be difficult to ensure that there is a sufficient “inertial response” to ensure engagement of the tool. However, on cross-examination, he admitted that he was not asked to provide an expert opinion on the validity of the API Patents. Therefore, I give no weight to his comments on Dr. Wooley’s testing methods and the validity of the claims of the API Patents in issue.

IX. Claim Construction

A. *Relevant Dates*

[115] The relevant date for construing the claims of each of the API Patents is the date of publication for each of the API patent applications:

- a. '467 Patent: September 5, 2000;
- b. '734 Patent: March 26, 2003; and
- c. '026 Patent: March 26, 2003.

[116] Construction is a question of law for the Court alone, and should be done before considering the issues of infringement and/or validity. The same interpretation of the claims applies to both infringement and validity: *Pfizer Canada Inc v Canada (Minister of Health)*, 2005 FC 1725 at para 10, aff’d 2007 FCA 1.

[117] The Supreme Court of Canada determined the canons of claim construction in a trilogy of cases: *Whirlpool Corp v Camco Inc*, 2000 SCC 67 at paragraphs 49-55 [*Whirlpool*]; *Free World Trust v Électro Santé Inc*, 2000 SCC 66 at paragraphs 44-54 [*Free World Trust*]; and

Consolboard Inc v MacMillan Bloedel (Saskatchewan) Ltd, [1981] 1 SCR 504 at paragraph 27
[*Consolboard*].

[118] These decisions state that:

- a. claims are to be read in an informed and purposive way, with a mind willing to understand and viewed through the eyes of a POSITA, as of the date of publication, having regard to the common general knowledge;
- b. adherence to the language of the claims allows them to be read in the manner in which the inventor is presumed to have intended, and in a way that is sympathetic to accomplishing the inventor's purpose, which promotes both fairness and predictability;
and
- c. the whole of the specification should be considered, in order to ascertain the nature of the invention, and the construction of the claims must be neither benevolent nor harsh, but instead should be reasonable and fair to both the patentee and the public.

[119] This Court recognizes that language is imprecise, and that words will have different meanings in different fields. Therefore, expert witnesses may aid the Court in construing either terms or elements of the claims, or in identifying "essential" elements of the claims. However, their assistance is only necessary when the Court deems it helpful or useful. If the meaning of a term is evident from the patent specification, the Court may not need expert assistance to determine the proper construction of terms used in the claims.

B. *The Person Skilled in the Art (POSITA)*

[120] The experts generally agreed on who would be the relevant POSITA with regards the API Patents. Dr. Sorem and Dr. Wooley testified that a POSITA would be either (1) a person with a Bachelor's degree in Mechanical Engineering, and one to three years of experience with downhole tools, which must include experience with torque anchors; or (2) a person without a degree but more significant work experience using and designing downhole tools, a period of at least five to ten years, which must include experience with torque anchors. Skoczylas testified that a POSITA should be a Registered Professional Engineer, or someone who is working under the supervision of a Registered Professional Engineer. Skoczylas appears to have ignored the "ordinary" part of the definition of "person of ordinary skill in the art" at the relevant time, and I find this threshold of being a Registered Professional Engineer inappropriate.

[121] The experts disagreed on the level of practical experience a POSITA would have with rotation of downhole tools. Dr. Sorem, on behalf of the API Parties, stated that a POSITA could not be expected to be aware of, or familiar with, downhole tools used in well drilling, since drilling and production are two distinct processes in oil well operation. Based on substantial evidence to the contrary from other witnesses, I disagree. Moreover, on cross-examination, Dr. Sorem also viewed himself as a POSITA. I have no doubt that, based on his lack of experience with torque anchors, Dr. Sorem would not be a POSITA. Therefore, the Court puts little weight on his testimony regarding the extent of experience needed for a POSITA at the relevant time.

[122] Having considered all the evidence before the Court, I find that the POSITA, in order to understand and be able to follow the specifications of the API Patents, would:

- a. have a Bachelor's degree in Mechanical Engineering, or a similar degree, and one to three years of practical experience with downhole tools used in oil well production, including experience with torque anchors; or
- b. have no formal degree, but five to ten or more years of experience with downhole tools used in oil well production, particularly the use of PC Pumps and torque anchors, and could as well have cross-over experience in drilling operations.

C. *Common General Knowledge*

- (1) Relevant dates for considering common general knowledge as it relates to anticipation and obviousness – the claim date (priority documents)

[123] The legal test governing a priority claim to an earlier filed application is set out in section 28.1 of the *Patent Act*, RSC, 1985, c P-4, which states that the date of a claim in an application (the "Claim Date") is the filing date of the application (defined in section 28), unless a proper request for priority to one or more earlier applications has been made. To qualify for a priority date, (a) the request for priority must have been made within 12 months of the earlier application, and (b) the subject matter defined by the claim in the application at the time of national entry in Canada must have been disclosed in the earlier filed application(s).

[124] The Claim Date for consideration of anticipation and obviousness for each patent is:

- a. the '467 Patent: March 5, 1999; and
- b. the '734 and '026 Patents: September 26, 2001.

(2) Common General Knowledge

[125] Common general knowledge is the knowledge generally known by the POSITA at the Claim Date when considering anticipation or obviousness; and the publication date of the patent when construing the patent's claims.

[126] What comprises common general knowledge has been articulated by this court in *Eli Lilly & Co v Apotex Inc*, 2009 FC 991 [*Eli Lilly 2009*], affirmed in 2010 FCA 240, at paragraph 97 (adopted from *General Tire & Rubber Co v Firestone Tyre & Rubber Co*, [1972] RPC 457 (UKHL) at 482-483):

1) Common general knowledge is distinct from what in patent law is regarded as public knowledge. Public knowledge is theoretical and includes each and every patent specification published, however unlikely to be looked at and in whatever language it is written. Common general knowledge, in contrast, is derived from a common sense approach to the question of what would be known, in fact, to an appropriately skilled person that could be found in real life, who is good at his or her job.

2) Common general knowledge will include patent specifications that are well known amongst those versed in the art. In particular industries, the evidence may show that all patent specifications form part of the relevant knowledge.

3) Common general knowledge does not necessarily include scientific papers, no matter how wide the circulation of the relevant journal or how widely read the paper. A disclosure in a scientific paper only becomes common general knowledge when it is generally known and accepted without question by the bulk of those engaged in the particular art.

4) Common general knowledge does not include what has only been written about and never, in fact, been used in a particular art.

[127] With regard to how to prove what comprises common general knowledge, Madam Justice Johanne Gauthier, in *Eli Lilly 2009*, above, at paragraph 100, quoted Simon Thorley et al., *Terrell on the Law of Patents*, 16th ed. (London: Sweet & Maxwell, 2006):

Proof of common knowledge is given by witnesses competent to speak upon the matter, who, to supplement their own recollections, may refer to standard works upon the subject which were published at the time and which were known to them. In order to establish whether something is common general knowledge, the first and most important step is to look at the sources from where the skilled addressee could acquire his information.

The publication at or before the relevant date of other documents such as patent specifications may be to some extent prima facie evidence tending to show that the statements contained in them were part of the common knowledge, but is far from complete proof, as the statements may well have been discredited or forgotten or merely ignored. Evidence may, however, be given to prove that such statements did become part of the common knowledge.

[128] Dr. Sorem stated that he did not believe that a POSITA would have experience in both oil well drilling and oil production, therefore, the '224 Burton Patent and the '843 Burton Patent would not have formed a part of the common general knowledge. Dr. Sorem opined that a POSITA in the art of anchoring PC Pumps would not look to lateral drilling for solutions. He further differentiated the fields of the invention by noting that the Burton Patents teach anchoring in an open hole, whereas the API Patents teach anchoring in a cased wellbore.

[129] I find that Dr. Sorem's testimony on what constitutes the common general knowledge at the relevant time to be unpersuasive. The expert evidence of Dr. Wooley and Skoczylas supports the position that a POSITA at the relevant times would have typically had some experience and

knowledge of both drilling and production operations, or at the very least had the where-with-all to look for solutions to problems in either field, by referring to both areas of operation.

[130] Based on the evidence given by the expert witnesses, the common general knowledge at the Claim Date for the '467 Patent (i.e., March 1999) would have included:

- a. general knowledge of downhole tools used in oil well production and drilling;
- b. the '224 Burton Patent;
- c. the '843 Burton Patent;
- d. the '693 Aldridge Patent; and
- e. the '239 Patent.

[131] Further, a POSITA would have understood the following, as part of the common general knowledge at the Claim Date for the '734 and '026 Patents (i.e., September 2001):

- a. the '467 Patent and use of the '467 TorqStopperTM torque anchors in oil production;
- b. the prior art listed in [130] above.

(3) Prior Art

[132] The three key patents that form part of the prior art as relied upon by the Excalibre Parties are the '224 Burton Patent; the '843 Burton Patent; and the '693 Aldridge Patent.

(a) *The '224 Burton Patent*

[133] The '224 Burton Patent was filed on May 12, 1986 and granted on October 13, 1987. It teaches a Method and Apparatus for lateral drilling in oil and gas wells involving a tool that is a directional drilling tool, which prevents downhole rotation of a pipe in a well. It discloses a tool comprising components needed for an improved lateral drilling technique that employs rotary drilling, using a flexible drill string connected by a flexible joint to a drill bit collar equipped with a stabilizer and rotary drill bit.

[134] The '224 anti-rotation tool has a radially extending wellbore engaging means to engage the surrounding borehole. The '224 Burton Patent states that the phrase "wellbore engaging means" refers to any structure located on the outside of the cylindrical collar opposite the side to which the central hole is displaced. In a disclosed embodiment, the radially extending wellbore engaging means is a plurality of spring steel fin members that are longitudinally attached to the collar and which displace the tool against the side wall of the borehole.

(b) *The '843 Burton Patent*

[135] The '843 Burton Patent was filed on July 2, 1987 and granted on April 26, 1988. The '843 Burton Patent also teaches a Method and Apparatus for lateral drilling in oil and gas wells, and discloses a directional drilling tool that prevents other downhole tools from rotating in the borehole. This patent discloses the use of at least one novel eccentric member with sidewall engaging means that attaches, or circumferentially mounts, to the downhole end of the flexible drilling string directly over the flexible joint leading to the drill bit collar.

[136] The tool disclosed by the '843 Burton patent is substantially similar to that disclosed in the '224 Burton Patent, but contains springs that give each fin an outward bias.

(c) *The '693 Aldridge Patent*

[137] The '693 Aldridge Patent was filed on April 9, 1997, and granted on June 13, 2000. The '693 Aldridge Patent discloses a torque anchor.

[138] The Aldridge anchor system consists of a central tube with a drag assembly located around the central tube, such that when the tubing is rotated, slip members that are originally in a retracted position are driven into an extended position, engaging the casing and preventing rotation. These slip members rotate through an arc to abut against sloped sides, which prevent them from rotating further. The housing carries at least two slip members.

D. *Claim Terms Needing Construction*

[139] The experts agreed that most of the terms in the API Patents can be given their ordinary meanings. However, there were four disputed terms that needed to be construed by the Court: “tubular”, “housing”, “casing-engaging wall”, and “first stop and second stop”.

(1) *Tubular*

[140] The experts had diverging opinions as to whether tubular means a hollow body of any shape, or a hollow, cylindrical body. Independent claims 1, 8, and 16 of the '467 Patent;

independent claims 1 and 16 of the '734 Patent; and independent claim 1 of the '026 Patent refer to a "tubular" housing for suspension in a wellbore casing.

[141] Dr. Sorem asserted that the word "tubular" does not imply any particular shape, but only references a hollow body with two openings at either end. He stated that tubing exists in many shapes, for example rectangular or oval tubing.

[142] In contrast, Dr. Wooley and Skoczylas, shared the opinion that tubing in oil and gas applications is always cylindrical. Skoczylas stated that in engineering fields, the word "tubular" usually means substantially circular in cross section, and implies a hollow body. In his opinion, most engineers would specifically state the shape of non-circular tubing, and would assume that tubing was circular if the shape was not otherwise stated. Skoczylas testified that he could not find any indication that the inventors of the API Patents considered the "tubular housing" to be anything other than substantially circular.

[143] In the context of torque anchors as described in the API Patents, and giving the term a purposive construction, I agree with the Excalibre experts that "tubular" means a hollow, cylindrical body, whose cross section is substantially circular.

(2) Housing

[144] The parties' experts disagreed on what a POSITA would understand when reading the term "housing". Specifically, there was disagreement as to whether a "housing" can include rigidly affixed, but removable, protruding components.

[145] Independent claims 1, 8, and 16 of the '467 Patent; independent claims 1 and 16 of the '734 Patent; and independent claim 1 of the '026 Patent refer to a tubular "housing" for suspension in a wellbore casing, and having at least one end for threaded connection to the downhole tool.

[146] Dr. Sorem testified that a housing includes anything that is affixed to the exterior body of the tool and is a permanent part of the tool when it is downhole. He opined that this includes anything that is not intended to move once the tool is assembled and that these components could be machined, welded, or bolted on to the housing. On cross-examination, Dr. Sorem agreed that the rigid slips on the CTA Torque Anchor are removable when the tool is up-hole, but asserted that they are affixed when the CTA Torque Anchor is downhole.

[147] In construing the claims of the API Patent and applying them in his infringement analysis, Dr. Sorem stated that a POSITA would understand that the torque anchor functions so that the jaw forces a side, or sides, of the housing against the casing. This results in a stationary section, or stationary sections, of the housing, including any affixed components, to contact the opposite side of the casing from the jaw.

[148] Skoczylas stated that a "housing", in engineering, including the field of downhole tools, is something that "houses" or encloses other components. He believed that a POSITA would not consider protrusions attached to a housing as part of the housing, but rather as distinct, separate components. During cross-examination, he qualified his position by stating that he would

consider “protrusions” to be different from milled-out sections, which could be considered part of the housing

[149] Skoczylas pointed to the use of the term “housing” in Canadian Patent No. 2,238,910 (the “’910 Patent”), which he believed a POSITA would be aware of at the relevant date of construction. In the ‘910 Patent, the inventor says in the abstract that “a fixed jaw ... projects outwardly from the housing”. Skoczylas opined that this use of the word “housing” would not support Dr. Sorem’s interpretation of the term and that a POSITA would not understand a “fixed” protrusion to be part of the housing.

[150] Skoczylas also opined that a POSITA would not consider protrusions to be part of the housing, which he supported with the fact that the means of centralizing the ‘467 TorqStopperTM torque anchor is not to use slips, even though slips would be an easier and less expensive way to accomplish the goal of centralization.

[151] In cross-examination, Skoczylas confirmed that his conclusions on the term “housing” were based upon prior art provided by counsel for the Excalibre Parties and his own general knowledge, referenced to the relevant dates. He admitted that he had not undertaken any independent search of the prior art regarding the term “housing”.

[152] While the Court has cautioned parties and counsel repeatedly against confining expert evidence to material provided solely by counsel, thus undermining expert independence in rendering opinions, this situation is different from the facts in *Astrazeneca Canada v Apotex Inc.*,

2015 FC 322 [*Astrazeneca 2015*], and *Uponor AB v Heatlink Group Inc and Pexcor Manufacturing*, 2016 FC 320 [*Uponor*]. In those cases, the experts carried out their obviousness analyses based solely on documents provided by counsel (see *Uponor*, above, at paras 203 to 204). In an obviousness analysis, a real risk created by selectively canvassing the prior art is offering a hindsight opinion. However, term construction is a retrospective inquiry into what a POSITA would have known at the relevant date and, therefore, there is necessarily a selection step to determine what prior art would form a part of the POSITA's common general knowledge.

[153] The API Parties argued that a POSITA would be aware of a much larger collection of torque anchors than those referenced by Skoczylas. However, they did not dispute that the patents used to by Skoczylas were part of the common general knowledge. Accordingly, while it was not improper for Skoczylas to construe the term "housing" in view of the prior art provided by counsel and his own knowledge at the relevant date for claim construction, it would have been preferable, and his opinion certainly of more weight, if he had conducted his own search of relevant prior art references. Therefore, I give limited weight to his opinion on this issue.

[154] Dr. Sorem's construction amounts to a tortured construction of the term "housing" and a misrepresentation of the way the tool operates, according to the Detailed Description of the Preferred Embodiment in the '467 Patent. The '467 Patent at page 7, lines 13 to 20 states:

In operation, as shown in Fig. 5a ... The housing wall 4 moves and also engages the casing 6, opposite the jaw 4 for anchoring and stabilizing the tool. ... the overall dimension of the extended jaw 5 and the housing 1 is greater than the diameter of the casing 6 so that contact of the radial tip edge 11 with the casing 6 forces the housing against the casing opposing the jaw.

[155] Figure 5a depicts the housing wall of the tool as being substantially a smooth, rounded surface. Therefore, to expand the construction of the claims of the '467 Patent to include a stationary section or sections of the housing, that are not the rounded surface of the housing, but protrusions used to contact the casing, is to improperly construe the term housing beyond what a reasonable, purposeful construction of the term would mean to a POSITA at the relevant publication dates of the API Patents.

[156] Finally, the Court notes that, in the Detailed Description of the Preferred Embodiment of the '467 Patent, the inventor states that “significant advantage is achieved by causing the tool’s housing 1 and its associated downhole tool (PC Pump) to rest against the casing 6”.

[157] Therefore, taking into account the testimony of the experts, the context of this technology, and giving the term a purposive construction, the term “housing” is a tubular body of the tool, not including removable protrusions that prevent a side of the attached downhole tool from engaging the casing. In particular, protrusions that are not permanently affixed to the central body should not be construed to be within the term “housing” as used in the API Patents.

(3) Casing-engaging wall

[158] The experts disagreed on the issue of whether the casing-engaging wall is limited to the rounded side of the housing, or if it can include projections from the housing. They further disagreed as to whether the casing-engaging wall has to be directly opposite the jaw, or whether it is any surface contacting the casing distinct from the jaw.

[159] Independent claims 1, 8, and 16 of the '467 Patent; independent claims 1 and 16 of the '734 Patent; and independent claim 1 of the '026 Patent refer to a "casing-engaging wall" that is on the opposing side of the housing from the pivot point of the jaw.

[160] Dr. Sorem stated that the term "casing-engaging wall" would not be interpreted as having any special shape or feature (i.e., the casing-engaging wall is not restricted to having a rounded surface). He opined that a POSITA would understand that, when operational, the tool described by the API Patents has a moving jaw on one side of the tool that contacts the casing, and a stationary section, or stationary sections, of the housing that contacts the opposite side of the casing from the jaw.

[161] Skoczylas disagreed with Dr. Sorem's statement that the "wall" of the housing is not restricted to having a particular shape or feature. Skoczylas referred to the American Petroleum Institute Specification 5CT, "Specification for Casing and Tubing" (6th Edition, published in October 1998), which he stated shows that the definition of the term "wall" is axiomatic. He suggested that a POSITA would consider the term "wall" to be axiomatic, and when considering the phrase "tubular housing having a wall" would not consider the wall of the housing to be anything but the substantially round side of the housing. He opined that, if protrusions were to be considered part of the casing-engaging wall, there would be ambiguity as to whether it was the protrusions or the wall of the round tubular portion of the tool body that engages the casing.

[162] Additionally, Skoczylas pointed to the "Background of the Invention" for the '467 Patent which states at lines 19 to 21 that the motion of the PC Pump stator is "in many cases supported

or restrained solely by the tool's slips", when torque anchors other than the '467 TorqStopper™ torque anchors are used to prevent rotation. His opinion was that this shows that the inventor of the '467 Patent considers his tool, in which the wall and not slips (or other protrusions) engages the casing, to be an improvement over the prior art.

[163] Taking into account the testimony of the experts, in the context of the patent specifications of the three patents in issue, and giving the term a purposive construction, I find that the term "casing-engaging wall" is the substantially round surface of the tubular housing opposing the jaw.

(4) "First Stop" and "Second Stop"

[164] Independent claim 1 of the '026 Patent refers to a "first stop formed on the base of the jaw" and a "second stop formed in the wall of the housing at the hinge". The experts disagreed as to whether the "stop" feature disclosed in the '026 Patent (the "'026 Stop") is necessarily different from the two points—one on the jaw and the other on the housing—that come in contact to limit the rotational range of the hinge attaching the jaw to the housing (the "Hinge Stop"). That is, they disagreed as to whether the '026 Stop created by the contact of the "first stop" and "second stop" functions in a manner that is distinct from the Hinge Stop.

[165] Claim 1 of the '026 Patent states that the “first and second stops co-operat[e] so as to limit maximum rotation of the jaw and to permit the effective diameter of the tool to increase to a diameter greater than the casing”. In the Description of the Preferred Embodiment, the function of these two stops is described as:

to arrest rotation of the jaw 105 and thereby restrict the amount the jaw 105 rotates radially outwardly from the housing 1, and to provide additional strength to the entire tool 10 so as to prevent damage which may occur when using power tongs or similar tools during the assembly of the tool 10 on the end of a tubing string or a specific downhole tool.

[166] Dr. Wooley testified that a POSITA would have understood that the Hinge Stop of the '467 TorqStopperTM torque anchor is functionally the same as the '026 Stop, although he acknowledged that it is in the wrong position to function to limit the rotation of the jaw in the manner indicated in the '026 Patent. He opined that because limiting rotation is the only function attributed to the '026 Stop in claim 1 of the '026 Patent, a POSITA would have interpreted the terms “first stop” and “second stop” to include the obstruction caused by the Hinge Stop.

[167] Skoczylas agreed that a POSITA at the relevant date would understand that the “first stop” is a component of the jaw that has neither a particular shape nor a particular orientation and the “second stop” is a component of the housing having neither a particular shape nor a particular orientation, because this was already taught by the prior art. However, he disagreed that the '026 Stop is distinct from the Hinge Stop, although he agreed that there is a difference in the geometry of the '026 Stop compared to the Hinge Stop. Skoczylas stated that the only difference between Hinge Stops previously described in the prior art and the '026 Stop is that the inventors of the '026 Patent prefer the “first stop” to be at the base, rather than the side, of the jaw.

[168] Dr. Sorem emphasized in his testimony that the '026 Stop, created by the cooperative action of the "first stop" and the "second stop", is distinct from the obstruction caused by the Hinge Stop. He interpreted the language describing the "first stop" as meaning that the "first stop" is a component of the jaw that has neither a particular shape nor a particular orientation. Similarly, he understood the language describing the "second stop" as meaning that the "second stop" is located on the housing, where the jaw is connected by the hinge to the housing, and that it has neither a particular shape nor a particular orientation. Finally, Dr. Sorem testified that the '026 Stop has to be something that improves the strength of the jaw, in addition to limiting its rotation.

[169] All of the experts agreed that Hinge Stops exist in the common general knowledge (e.g., Canadian Patent No. 2,177,726 and '693 Aldridge Patent). Dr. Wooley and Skoczylas stated that a POSITA would have interpreted the terms "first stop" and "second stop" with this art in mind. However, the Excalibre experts opined that the language of claim 1 is too narrow for the function of the '026 Stop to encompass a jaw strengthening feature, when the terms "first stop" and "second stop" are properly construed. This approach shows that their construction did not consider the '026 Patent specification contextually, nor does it demonstrate a "mind willing to understand", since the specification makes it clear that strengthening the jaw against torquing forces up-hole is a benefit of the '026 Stop feature.

[170] Based on all the evidence presented, I find the term "first stop" as used in the '026 Patent includes any component formed on the base of the jaw that cooperates with the "second stop" to limit the rotation of the jaw and strengthen the jaw when the tool is up-hole. The term "second

stop” includes any component in the wall of the housing, at the hinge, that cooperates with the “first stop” to limit the rotation of the jaw and strengthen the jaw when the tool is up-hole. The ‘026 Stop is created by the cooperative engagement of the “first stop” and “second stop”.

X. Ownership of the API Patents

[171] The Excalibre Parties neither made arguments nor adduced evidence contesting the validity of the assignment of the API Patents to Weber, Tessier, and Doyle. In fact, they agreed to the validity of the assignment. In any event, based on the evidence before the Court, I find that there was a valid assignment of the API Patents to Weber, Tessier, and Doyle.

XI. The Tests of the TorqStopperTM Torque Anchors

[172] The experts for both parties carried out tests to investigate whether the claims of ‘467 TorqStopperTM torque anchors were invalid for inutility. However, all of the tests were done in laboratory environments, with little or no effort by the experts to ensure that real oil well operations and conditions making use of torque anchors were being replicated. As such, the majority of the test results are of little probative value, and the only compelling evidence of the utility of the ‘467 Patent claims is the evidence provided by the fact witnesses, Van Metre and McGowan.

[173] In this case, *in situ* testing would have been the most persuasive testing to show utility or lack of utility for various torque anchors, because it would have demonstrated the actual performance of the torque anchors covered by the API Patents in issue. Barring the availability

of *in situ* testing, experts should be mindful of the real world application of an invention when designing testing methods. Real world application of torque anchors was at best inconclusive in the tests carried out by both parties, as discussed below.

A. *Excalibre Parties testing at the C-FER Laboratories on July 30, 2014 and July 31, 2014*

[174] Tests were performed at the C-FER Laboratories in Edmonton, Alberta on July 30, 2014 (the “2014 C-FER Tests”). These tests were conducted, on behalf of the Excalibre Parties, to evaluate whether the ‘467 Patent described all of the necessary features that would enable a POSITA to utilize the invention disclosed by the ‘467 Patent, and whether the invention would work. In particular, these tests were designed to evaluate whether the ‘467 TorqStopper™ torque anchor would function as needed without a biasing spring, which is disclosed in the subsequent ‘734 and ‘026 Patents. The details of the procedure and results of the 2014 C-FER Tests are described in Dr. Wooley’s expert report.

[175] The 2014 C-FER Tests were performed on three different TorqStopper™ torque anchors: two used TorqStopper™ tools brought by the Excalibre Parties—an old design TorqStopper™ TX5-2 torque anchor (no spring) and old design TorqStopper™ TX5-2 torque anchor (with spring); and a newer TorqStopper™ TX5-3 torque anchor (with spring). Both of the used TorqStopper™ TX5-2 tools had marks indicative of make-up and running in a well. The TorqStopper™ TX5-3 torque anchor was newly purchased by the Excalibre Parties, and brought for the tests by the API Parties. Tessier, representing the API Parties, was present at the 2014 C-FER Tests and did not take issue with whether any of these tools were genuine TorqStopper™ tools.

[176] A total of 22 tests were run: two on the used TorqStopper™ TX5-2 torque anchor (no spring) in air; three on the used TorqStopper™ TX5-2 torque anchor (with spring) in air; 8 on the used TorqStopper™ TX5-2 torque anchor (spring removed) in air; five on the TorqStopper™ TX5-3 torque anchor (spring removed) in air; and four on the TorqStopper™ TX5-3 torque anchor (spring removed) in oil. To perform the tests, operators screwed the TorqStopper™ tool in question onto a pup joint of tubing, and lowered the tool and tubing assembly into a casing stand. Once inside the casing stand, the tool was rotated to the left (counter-clockwise) for one turn, and then to the right (clockwise) five turns. On nine of the tests, the operators centered the tubing and tool assembly in the casing with ball bearings. They also performed tests varying the angle of the casing from vertical to 5, 10 or 28 degrees from vertical.

[177] When the TorqStopper™ TX5-2 torque anchor (with spring) was rotated clockwise, the jaw engaged with the casing almost immediately. However, the TorqStopper™ TX5-2 torque anchor (no spring), the TorqStopper™ TX5-2 torque anchor (spring removed) and the TorqStopper™ TX5-3 torque anchor (spring removed) did not contact the casing when rotated clockwise. The operators did not rotate any tool more than five turns, nor did they vary the speed of rotation.

[178] On July 31, 2014, subsequent testing was conducted at the C-FER Laboratories to examine whether the TorqStopper™ TX5-3 torque anchor (spring removed) would behave differently at an angle of 90 degrees from vertical, with oil in the casing. The results of these tests showed that the TorqStopper™ TX5-3 torque anchor (spring removed) did not engage the casing when in a horizontal position.

[179] Dr. Sorem criticized the protocol used in the 2014 C-FER Tests because the tools were not tested in a control condition where the tester showed that the tools could work and set. Since there was no control test and none of the tools tested set, in his opinion the testing procedure could not be relied upon.

[180] I agree that the 2014 C-FER Tests are of limited probative value. During cross-examination, Dr. Wooley admitted that the TorqStopper™ TX5-2 torque anchor (no spring) tool had been fished out of a well, and that he never tested whether it could be set, meaning that the tool may not have set because it was defective. He also did not consider or attempt to replicate real world well conditions, making it difficult to rely on the tests to draw conclusions about how the ‘467 TorqStopper™ torque anchors would have behaved in the field. Additionally, the rotational speed at which the tests were conducted is highly problematic. The Court heard testimony from rig operators that the speed used in the 2014 C-FER Tests was very slow and not representative of setting procedures in the field. The fact that Dr. Wooley chose a test speed that was much slower than would or could be used by operators setting ‘467 TorqStopper™ torque anchors is a significant flaw in the testing methodology. Therefore, the test results are of very limited probative value, if any, in discerning whether the three tools tested by Dr. Wooley would set outside of the limited testing conditions used at C-FER.

[181] Finally, during direct examination, Dr. Wooley, when viewing video of the TorqStopper™ torque anchors without springs stated “it’s not surprising that the spring-biased ones with the smaller jaws would not [set when the spring was removed] ...”; “... the TX5-2 [sic] model without the spring, of course, will not set without the spring bias”; and “as you

would expect, [the TorqStopper™ TX5-2 torque anchor centered with ball bearings] does not set after turning to the right.” These comments suggest that Dr. Wooley did not approach the 2014 C-FER Tests with a “mind willing to understand”, but with a pre-conceived view as to the result he sought to prove—the inutility of both the ‘467 Patent claims and the tool that embodies those claims. His predisposition to find the answer he wanted to prove showed a tainted approach to the experimental testing.

B. *Testing at the API Facilities on January 12, 2015*

[182] Dr. Sorem performed utility tests on a ‘467 TorqStopper™ torque anchor at the API facilities on January 12, 2015 (the “API Tests”). These tests were conducted to demonstrate that a ‘467 TorqStopper™ torque anchor would set in casing. The details of the testing procedure and the results are described in Dr. Sorem’s validity report.

[183] To perform these tests, operators attached the ‘467 TorqStopper™ torque anchor to a tubular, which was supported at the top of the casing by a split collar, allowing the tool to rotate with very low torque. The ‘467 TorqStopper™ torque anchor was rotated clockwise to “set”, and after each “set” the operator applied as much weight as he could to demonstrate that setting was achieved.

[184] Operators ran dry tests to test how the tool set at various casing angles (i.e. every 30 degrees from horizontal to vertical). Additionally, the operators ran oil tests at vertical and 30 degrees from vertical, where the casing was filled with Pennzoil Gearplus 80W-90 GL-5 gear oil to a level above the tool.

[185] In each test, the tool set successfully and anchored in less than one and one-half rotations. The API Tests demonstrated that a '467 TorqStopperTM torque anchor could set under the conditions tested, and would prevent rotation of a downhole tool in casing under the same conditions.

[186] However, Dr. Sorem stated that he and Tessier did not discuss a particular rotational speed, or range of speeds, at which to rotate the '467 TorqStopperTM torque anchor in the tests, but rather decided to use the "fastest speed a man could achieve with a chain wrench". On cross-examination, he admitted that, when deciding upon the protocol for the API Tests, he did not do an investigation of the typical torque anchor setting protocol in the field; rather he followed the protocol set out by Tessier. Additionally, although he thought that operators at the 2014 C-FER Tests rotated the TorqStopperTM torque anchors at an "arbitrarily slow speed", he conceded that he had no frame of reference for what would be an appropriate setting speed other than the speed at which the API Tests were conducted, as directed by Tessier.

[187] Similar to the 2014 C-FER Tests, I find that the API Tests are of limited probative value. Dr. Sorem did not consider whether the testing method represented a real world situation and did not independently investigate how a typical torque anchor would be set in the field. In fact, he testified that Tessier had significant input into the testing methodology. Further, Dr. Sorem made no attempt to quantify the rotational speed necessary to set the tools. Based solely upon these tests, it is at best uncertain whether the '467 TorqStopperTM torque anchor would set in an oil well.

C. *Demonstrative Testing at C-FER on January 13, 2015*

[188] Tests were performed at the C-FER Laboratories on January 13, 2015 (the “Demonstrative Tests”). The purpose of these tests was to determine whether the addition of slips to a TorqStopperTM torque anchor impacted its function, and whether the removal of the slips from a CTA Torque Anchor Version 6 (a “CTA 6”) impacted its function. The details of the testing procedure and the results are described in Skoczylas’ expert report.

[189] Skoczylas performed the tests using the TorqStopperTM TX5-3 torque anchor that was used by Dr. Wooley in the 2014 C-FER Tests, and a CTA 6. The procedure for testing whether the tools would engage with the casing was the same as the procedure use in the 2014 C-FER Tests.

[190] The tests with the CTA 6 showed that the tool’s jaw was not in a “stowed” position, as taught by the ‘467 Patent, when the tool is rotated left (counter-clockwise) in the casing. Instead, the jaw was in full contact with the casing wall. When the slips of the CTA 6 were removed and the tool was turned right (clockwise), it failed to set. Additionally, when the slips were reinstalled on to the CTA 6, but the springs of the jaw removed, the tool failed to set.

[191] When the TorqStopperTM TX5-3 torque anchor was tested in the casing, it turned freely when turned to the left (counter-clockwise) and set quickly when turned to the right (clockwise). To determine whether slips would be a substitutable element to the round, substantially smooth housing, Skoczylas milled slots into the housing of the TorqStopperTM TX5-3 torque anchor and

transferred the slips from the CTA 6 to the TorqStopper™ TX5-3 torque anchor. In this configuration, it was found that the TorqStopper™ TX5-3 torque anchor would not fit within the casing.

[192] Once again, the testing is of limited probative value based on the methodology used. These tests did not validate any of the points made by Skoczylas about the material effects of adding slips to the TorqStopper™ torque anchor, nor did they elucidate any of his statements regarding infringement. Due to the narrow parameters of these tests, it is difficult for the Court to make any conclusions about how the addition of slips would affect the function of a TorqStopper™ torque anchor in an oil well.

XII. The Law – Principles of Utility, Anticipation, Obviousness, and Infringement

A. *Utility*

[193] Section 2 of the *Patent Act* requires that the subject matter of a patent be both new and useful. The general principle is that, as of the date of filing, there must have been either a demonstration of the utility of the invention or a sound prediction of its utility (*Eli Lilly Canada Inc v Novopharm Ltd*, 2010 FCA 197 at para 74 [*Eli Lilly 2010*]) The Supreme Court of Canada

in *Consolboard*, above, at 525, adopted the definition of utility in Halsbury's Laws of England, (3rd ed.), column 29 at 59:

[not useful means] the invention will not work, either in the sense that it will not operate at all or, more broadly, that it will not do what the specification promises that it will do ... practical usefulness of the invention does not matter, nor does its commercial utility, unless the specification promises commercial utility, nor does it matter whether the invention is of any real benefit to the public, or particularly suitable for the purposes suggested.

[Footnotes omitted]

[194] Although the issues of “promise of the patent” and utility have overlapping aspects, the test for utility is distinct from the test for “promise of the patent”. Where the patent specification does not promise a specific result, for an invention to be useful, a “mere scintilla” of utility will suffice (*Eli Lilly 2010*, above, at para 76).

B. *Anticipation*

[195] Mr. Justice Rothstein, in *Sanofi*, at paragraph 25, stated that anticipation is found where performance of the prior art necessarily infringes the patent under review. He explained that both disclosure and enablement are required for a prior art reference or prior use to be held to anticipate a claim in a patent (*Sanofi*, at paras 26 to 27).

[196] Disclosure and enablement are two separate requirements for anticipation. At the disclosure stage, the prior patent must disclose subject matter that would infringe the patent under review if performed (*Sanofi*, at para 25). That is, the POSITA reading the prior patent,

with no trial and error, must be able to understand whether it discloses the special advantages of the patent under review (*Sanofi*, at para 32).

[197] At the enablement stage, the question becomes whether the POSITA would be able to work the invention disclosed by the prior patent, with a reasonable amount trial and error allowed (*Sanofi*, at para 27). What constitutes a reasonable amount of trial and error is set out, in *Sanofi* at paragraph 37, by Mr. Justice Rothstein as follows:

... When considering whether there is undue burden, the nature of the invention must be taken into account. For example, if the invention takes place in a field of technology in which trials and experiments are generally carried out, the threshold for undue burden will tend to be higher than in circumstances in which less effort is normal ... But experiments or trials and errors are not to be prolonged even in fields of technology in which trials and experiments are generally carried out. No time limits on exercises of energy can be laid down; however, prolonged or arduous trial and error would not be considered routine.

[198] In *Shell v Commissioner of Patents*, [1982] 2 SCR 536 at 549, Madam Justice Wilson stated that the discovery of a new use for an invention, which is capable of practical application, is an “invention” within the meaning of the *Patent Act*. Therefore, a patent cannot be anticipated if it is directed to a different use from the allegedly anticipatory patent.

C. *Obviousness*

[199] The four-part test for obviousness was set down by the Supreme Court of Canada in *Sanofi*, at paragraph 67—which follows the approach outlined by Oliver L.J. in *Windsurfing*

International Inc v Tabur Marine (Great Britain) Ltd, [1985] RPC 59 (CA), and updated by Jacob L.J. in *Pozzoli SPA v DBMO SA*, [2007] FSR 37, [2007] EWCA Civ 588, at paragraph 23:

In the result I would restate the *Windsurfing* questions thus:

- (i) Identify the notational “person skilled in the art”;
- (ii) Identify the relevant common general knowledge of that person;

Identify the inventive concept of the claim in question or if that cannot readily be done, construe it;

Identify what, if any, differences exist between the matter cited as forming part of the “state of the art” and the inventive concept of the claim or the claim as construed;

Viewed without any knowledge of the alleged invention as claimed, do those differences constitute items which would have been obvious to the person skilled in the art or do they require any degree of invention?

[Emphasis added]

[200] In areas where advances are often found through experimentation, an “obvious to try” test can be appropriate (*Sanofi*, at para 68). It is at the fourth step of the *Windsurfing/Pozzoli* approach that the issue of “obvious to try” will arise, and the following, non-exhaustive, factors will apply in accordance with the evidence of each case (*Sanofi*, at para 69):

- 1) It is more or less self-evident that what is being tried ought to work? Are there a finite number of identified predictable solutions known to persons skilled in the art?
- 2) What is the extent, nature and amount of effort required to achieve the invention? Are routine trials carried out or is the experimentation prolonged and arduous, such that the trials would not be considered routine?
- 3) Is there a motive provided in the prior art to find the solution the patent addresses?

[201] Obviousness is a difficult test to meet. It is necessary to show that the skilled person would have come directly and without difficulty to the invention; and, because hindsight is 20-20, measuring references to find an invention “obvious” should be scrutinized carefully by the Court (*Bridgeview Manufacturing Inc v 931409 Alberta Ltd (cob Central Alberta Hay Centre)*, 2010 FCA 188 at paras 50 to 51; *Sanofi*, at para 85). Particularly, the Court must ensure that the reference for the test of obviousness is a technician, who is skilled in the art, but possesses no scintilla of inventiveness or imagination (*Beloit Canada Ltd v Valmet OY* (1986), 8 CPR (3d) 289 at 294).

[202] Finally, as stated by Madame Justice Snider for guidance in *Sanofi-Aventis Canada Inc v Apotex Inc*, 2009 FC 676 at paragraph 267, affirmed in 2011 FCA 300:

As expressed by Justice Rothstein in *Sanofi-Synthelabo*, obviousness of the "invention" is to be measured. However, it appears to me that the assessment must be focused on the "inventive concept of the claim in question" and not to some larger "invention" that might be described in the specification of the patent. Otherwise, we would have the illogical result that a finding of obviousness could invalidate all of the claims in a patent and not just those in issue. Thus, I will proceed with my analysis on the basis that the "invention" or "inventive concept" being examined is limited to those "inventions" as identified by Claims 1, 2, 3, 6 and 12.

D. *Infringement*

[203] It is settled law that “a patent owner has a remedy against an alleged infringer who does not take the letter of the invention but nevertheless appropriates its substance” (*Free World Trust*, above, at para 28). However, it is equally settled that the Court must be careful not to construe the claims of a patent so broadly such that it confers onto the patentee the benefit of

inventions not in fact made. In *Free World Trust*, at paragraph 30, Mr. Justice Binnie enumerated six propositions that must be considered ensure that a fair and predictable result is achieved while construing claims to determine whether there is infringement:

1. The *Patent Act* promotes adherence to the language of the claims.
2. Adherence to the language of the claims in turn promotes both fairness and predictability.
3. The claim language must, however, be read in an informed and purposive way.
4. The language of the claims thus construed defines the monopoly. There is no recourse to such vague notions as the “spirit of the invention” to expand it further.
5. The claim language will, on a purposive construction, show that some elements of the claimed invention are essential while others are non-essential. The identification of elements as essential or non-essential is made:
 - a. on the basis of the common knowledge of the worker skilled in the art to which the patent relates;
 - b. as of the date the patent is published;
 - c. having regard to whether or not it was obvious to the skilled reader at the time the patent was published that a variant of a particular element would *not* make a difference to the way in which the invention works; or
 - d. according to the intent of the inventor, expressed or inferred from the claims, that a particular element is essential irrespective of its practical effect;
6. without, however, resort to extrinsic evidence of the inventor’s intention.
7. There is no infringement if an essential element is different or omitted. There may still be infringement, however, if non-essential elements are substituted or omitted.

[204] The interpretive task of the Court, therefore, is to purposively construe the claims of a patent to define the scope of the patent holder's monopoly, and then determine whether the allegedly infringing product falls within the scope of those claims (*Mobil Oil Corp v Hercules Canada Inc* (1995), 63 CPR (3d) 473 at 489; *Free World Trust* at paras 48 to 49).

XIII. The '467 Patent

A. *Utility*

[205] Dr. Sorem and Dr. Wooley disagreed as to whether the '467 Patent discloses a useful invention.

[206] Dr. Sorem's position was that the API Tests, which show the '467 TorqStopperTM torque anchor engaging and anchoring in every test, should be preferred to the 2014 C-FER Tests, because the API testers rotated the tool continuously at a reasonable speed, whereas the 2014 C-FER testers rotated the tool at a speed that was, in his opinion, both extremely slow and not continuous. He disagreed with Dr. Wooley's conclusion that "attempting to set [the tool] by rotating at higher speeds or more turns would not be practicable in a real world situation". Further, he opined that the '467 TorqStopperTM torque anchor used in the 2014 C-FER Tests (i.e., the TorqStopperTM TX5-2 torque anchor (no spring)) should not be considered reliable, because it was a tool that was fished from a well, and there are neither records available as to where or when the tool was obtained, nor records of the tool's service history.

[207] He also opined that the API Tests, in addition to the testing done by Tessier at the time the patent application was submitted, demonstrated that a tool embodying the '467 Patent meets the utility requirement. However, on cross-examination, Dr. Sorem admitted that he did not examine or test the methodology used in Tessier's original tests, and that he accepted Tessier's assertions that the '467 TorqStopperTM torque anchor set in those original tests at face value.

[208] I give Dr. Sorem's evidence limited weight on this issue, because of his reliance on the results of the API Tests, Tessier's assertions, and his lack of practical experience in the oil and gas industry. As discussed above, the API Tests are not reliable proof that a '467 TorqStopperTM torque anchor will set in an oil well. Further, since he did not investigate, nor have any experience in, real world oil well conditions, he cannot comment on whether or not the 2014 C-FER Tests are reliable.

[209] Dr. Wooley regarded the 2014 C-FER Tests as definitively showing that a tool embodying the '467 Patent does not engage the casing. He concluded that a torsional spring, such as the spring disclosed in the '734 Patent, is a necessary element for the tool to reliably engage the casing, and that without a spring to bias the jaw outward, a tool embodying the claimed invention of the '467 Patent would not function as expected.

[210] Dr. Sorem critiqued Dr. Wooley's removal of the springs from the TorqStopperTM TX5-2 torque anchor (with spring) and the TorqStopperTM TX5-3 torque anchor in the 2014 C-FER Tests. He noted that the TorqStopperTM TX5-3 torque anchor was specifically designed to use a spring, rather than inertia, to actuate downhole and hypothesized that the jaw of the

TorqStopper™ TX5-3 torque anchor may be designed with less mass than a tool that was designed to function without the spring component. He posited that the modified TorqStopper™ TX5-3 torque anchor may have a low inertia response; therefore, Dr. Wooley, by removing the spring, rendered the tool inoperable and the results unreliable.

[211] When questioned about the 2014 C-FER Tests on direct examination, Dr. Wooley commented that the springless tools did not set after turning to the right “as you would expect”. As stated above, his comment suggests that he approached the 2014 C-FER Tests with a preformed opinion on how the springless tools would perform. Additionally, during his direct examination on the video of the 2014 C-FER Tests, counsel for the Excalibre Parties provided Dr. Wooley with a document that included commentary extrinsic to his expert report. I question the reliability of his testimony given that this “cheat sheet” was obviously leading and improperly put to him on the witness stand.

[212] Moreover, on cross-examination, Dr. Wooley also admitted that his instructions were to look at the ‘467 Patent and focus on the fact that it does not disclose a spring. He further conceded that he had no knowledge of the provenance of the TorqStopper™ TX5-2 torque anchor (no spring) tool, but that he thought that it was fair to test a tool that had been fished from a well, even though the fact that it had been fished from a well meant that this particular tool had failed in the past. He also acknowledged that he never performed any control experiments to ensure that the tool was functional. With respect, this failure to undertake basic, reasonable control tests not only suggests, but confirms, that Dr. Wooley did not approach the 2014 C-FER Tests with a “mind willing to understand”, but with a pre-conceived view as to the result he

sought to prove—the inutility of both the ‘467 Patent claims and the tool that embodies those claims. The opinion expressed by Dr. Wooley on inutility of the ‘467 Patent claims fails to demonstrate the necessary impartiality of expert witnesses required by this Court, and smacks of advocacy for a predetermined outcome. Therefore, I find that the results of 2014 C-FER Tests and his opinion on utility provide little, if any, objective analysis concerning the utility of the claims of the ‘467 Patent.

[213] In conclusion, the expert testimony for both the Excalibre Parties and the API Parties was weak, with little probative value on the issue of utility of the ‘467 Patent claims.

[214] The testimony of Van Metre and McGowan, who had both personally set many ‘467 TorqStopperTM torque anchors in the field successfully, was straight-forward and matter of fact. I find their testimony credible, particularly that of Van Metre, who had no business interest in the outcome of these proceedings. Their evidence is the most compelling evidence of utility of the ‘467 invention as described and claimed.

[215] Additionally, and not to be confused with commercial success as an indicator of non-obviousness, the documentary evidence shows that the ‘467 TorqStopperTM torque anchor was commercially viable and used successfully by various customers in the field, which serves as an indicator that end users in the oil and gas industry found the invention useful. Counsel for the Excalibre Parties vigorously argued that ‘467 TorqStopperTM torque anchor was not sufficiently reliable for oil well applications and that it was not a commercial success. That is not the test for patent utility, which is measured on a different threshold, and the evidence before the Court

satisfies me that the ‘467 TorqStopperTM torque anchor was useful. As such, the utility requirement of the claims of the ‘467 Patent has been met.

[216] Therefore, considering all the evidence, I find that the ‘467 Patent discloses a useful invention.

B. *Infringement*

[217] The experts agreed that the ‘467 Patent has three independent claims: claims 1, 8, and 16 (see above). They also agreed that claims 8 and 16 are substantially the same as claim 1. Thus, to determine whether the ‘467 Patent is infringed by any version of the CTA Torque Anchor, the Court can determine whether any of the essential elements of claim 1 are different from or omitted in any version of the CTA Torque Anchor, meaning that those tools do not infringe, and apply this analysis to claims 8 and 16.

[218] There was no dispute that a jaw, pivotable upon rotation of the tool, is an essential element of claim 1. Nor was there any dispute that it is an essential element that the jaw has a casing-engaging position that is engaged by rotation and the jaw’s inertial response.

[219] I heard considerable testimony on the issue of whether a POSITA would have considered it essential for the substantially rounded side of the housing, the wall, to contact the casing, as discussed above in construing the housing and casing-engaging wall.

[220] Dr. Sorem found that the elements of claim 1 are present in all versions of the CTA Torque Anchor. Specifically, all CTA Torque Anchors have a tubular housing which is threadedly connected to the downhole tool, and have a wall of the tubular housing—which, in his opinion, included non-moveable slips which are rigidly attached to the body—that engages the casing when the tool is actuated.

[221] Skoczylas was instructed to consider the “Improver Analysis” from *Free World Trust* to determine the essential elements of the ‘467 Patent. His understanding was that this analysis required him to ask (1) whether a housing with external slips has a material effect on the way the CTA Torque Anchors work, as compared to the ‘467 TorqStopper™ torque anchor; and (2) would the POSITA have understood from the language of the claims in the API Patents that strict compliance with the primary meaning was an essential requirement of the invention.

[222] Skoczylas stated that in advertising the TorqStopper™ torque anchors, API touts the advantages of a tool that does not have slips by stating that there is more room for gas breakout with the TorqStopper™ torque anchor as compared to a tool that resembles the CTA Torque Anchors. Additionally, the inventors of the API Patents give the POSITA reason to infer that a “simplified anti-rotation tool [with] only one moving part” is a material improvement upon a device with slips. Therefore, in his opinion, API believes there is a material effect of adding slips to the housing, and they consider slips to be a negative feature.

[223] While advertising materials may be noteworthy, they are not relevant to construing claims, as being extraneous documents to the patent specification being considered.

[224] Skoczylas suggested that a POSITA would see at least three material effects of adding slips:

1) If there is any sand production in the well, the device with slips lifts the body of the tool out of the sand bed. This would mean that the tool with slips would be more easily removed. This benefit is mentioned in CA Patent 2,611,294 (the “’294 Patent”).

2) If the oil and gas producer needs to install instrumentation below the pump (e.g., pressure or temperature sensors), which involves running a small cable past the pump and torque anchor, the device with slips has a means of protecting the cable from being squeezed between the casing and the tool body. This benefit is also mentioned in the ‘294 Patent.

3) The nature of the contact between the tool and the casing wall is clearly different between a tool with slips and a tool without. With two slips, in addition to the jaw, torque may be resisted at three points, instead of at a round surface, which would lead to better engagement of the casing wall under load.

[225] On cross-examination, Skoczylas admitted that he had not conducted any tests to prove that these material effects exist, and that these statements about material effects are based solely on his personal experiences with other oil and gas tools.

[226] Skoczylas opined that, in all of the figures in the API Patents, the casing-engaging contact is always shown to be a round tubular wall. No version of the CTA Torque Anchor has a wall of the tubular housing that engages the casing. The rigid slips of the CTA Torque Anchors, which contact the casing, create discrete points of contact with the casing. He argued that this is a different casing contact profile from that created by contact of the casing with the rounded side of the housing, which is a diffuse contact over a large surface area. He testified that this would differentially affect the stabilizing abilities of the tools.

[227] Skoczylas also opined that the moving slip on all versions of the CTA Torque Anchor does not have a pivot point that is opposite the housing's casing-engaging wall for two reasons: (1) there is no casing-engaging wall on the housing because of the slips; and (2) the CTA Torque Anchors engage the wall at two discrete points, which are widely separated. He contended that it is impossible for a single point to be opposite two discrete and separated points.

[228] In light of Dr. Sorem's tortured interpretation of the term housing, discussed above, I prefer Skoczylas' evidence on this issue. My opinion is that a POSITA, at the time the '467 Patent was published, would not have understood that multiple contact points were an obvious variant of contact along the length of the casing-engaging wall of the housing.

[229] The experts also disagreed as to whether it is essential to the '467 TorqStopperTM torque anchor's function for the jaw to have a stowed position against the housing. Given the evidence, I am convinced that a POSITA would consider the ability of the jaw to move to a position that permits the tool to move past obstructions in the casing to be an essential element. However, an actual "stowed position against the housing", where the jaw is not in contact with the casing, is not essential.

[230] After purposively construing these terms, I conclude that claims 1, 8 and 16 of the '467 Patent have the following essential elements:

- a. a tubular housing;
- b. a wall of the housing that engages the casing (i.e., a casing-engaging wall);

- c. a jaw, with a radial tip, that is pivotable upon rotation of the tool around a hinge that is opposite the casing-engaging wall;
- d. an inertial response;
- e. a mechanism for stowing the jaw against the housing to minimize the tool's effective diameter; and
- f. a casing-engaging position that is engaged by the jaw's inertial response to rotation.

[231] Considering the constituent elements of all versions of the CTA Torque Anchor, I find that no version of the CTA Torque Anchor infringes claims 1, 8, or 16 of the '467 Patent. The CTA Torque Anchors do not have a casing-engaging wall. It is the rigid slips, not the wall of the housing, that contact the casing when all versions of the CTA Torque Anchor are set.

Additionally, the casing-engaging position of the movable slip in all versions of the CTA Torque Anchor is not actuated via an inertial response, because the movable slip is spring biased.

XIV. The '734 Patent

A. *Anticipation – '843 Burton Patent*

[232] The Excalibre Parties claimed that the '734 Patent is anticipated by the '843 Burton Patent. However, they adduced little evidence as to whether the '843 Burton Patent either disclosed or enabled the invention taught by the '734 Patent. As discussed above, the '843 Burton Patent discloses a drill collar used in directional drilling.

[233] It is clear that preventing rotation of downhole tools during oil production is different from directional drilling. Therefore, I find that the '734 Patent is not anticipated by the '834 Burton Patent.

B. *Anticipation – Prior Use*

[234] The Excalibre Parties sought to further amend their Statement of Claim four days before the trial began. Their proposed amendments included pleadings regarding anticipation of the '734 and '026 Patents by enabling disclosure through prior sale or use of the '467 TorqStopper™ torque anchors. After considering the applicable test for a motion seeking leave to amend a pleading, and finding that the prejudice that the amendments would cause to the API Parties could not be compensated by an award of costs, I denied the amendments (*Continental Bank Leasing Corp v Canada*, [1993] 1 CTC 2306; (1993), 93 DTC 298 (TCC); *Merck & Co v Apotex Inc*, 2003 FCA 488 at para 10; *Sanofi-Aventis Canada Inc v Teva Canada Limited*, 2014 FCA 65).

C. *Obviousness*

[235] The experts agreed that the allegedly inventive step disclosed by the '734 Patent over the '467 Patent is the addition of the spring mechanism to bias the jaw, disclosed in claim 1. Claim 1 of the '734 Patent discloses “a spring, acting between the jaw and the housing so as to bias the jaw outwardly ... wherein the spring is a torsional member extending substantially axially along the tubular housing”. However, they disagreed on whether a POSITA would have understood a torsional member to be equivalent to a more generic spring. During the trial, the terms leaf

spring, coiled spring, torsional spring, and torsional member were used, sometimes interchangeably, to describe the biasing mechanism disclosed by the '734 Patent.

[236] Dr. Sorem disputed that a “spring is a spring, is a spring”. He insisted that the three types of spring are distinct—particularly that a torsional spring is not the same as a torsional member, and that a leaf spring is a completely different type of spring used in bending, not biasing, applications. Further, he maintained that torsional members provide particular benefits.

[237] Dr. Sorem was consistent in his usage of the three terms, but agreed that a torsional spring could be described as a coiled spring. Dr. Wooley and Skoczylas used the terms torsional spring, coiled spring, and torsional member interchangeably. During both direct examination and cross-examination, Tessier used the terms torsional spring and torsional member interchangeably, but seemed to distinguish both from a coiled spring.

[238] Dr. Wooley testified that there is no functional difference between a torsional spring and a torsional member. Additionally, a POSITA, knowing of the '843 Burton Patent, would have thought it more or less self-evident that the solution to the problem of the '467 TorqStopperTM torque anchor failing to set was to add a spring to bias the jaw outward. He stated that the design of the jaw of the '467 Patent would make a torsional spring the obvious choice. He also opined that because the '693 Aldridge Patent discusses and explicitly teaches away from the '239 Patent, which uses spring actuated slips, a POSITA would be aware of the possibility of using springs to actuate slips ('693 Aldridge Patent, column 1, lines 35 to 36).

[239] On cross-examination, counsel for the API Parties challenged Dr. Wooley about his failure to distinguish between torsional springs and torsional members. Dr. Wooley responded that it was his opinion that an engineer would see a torsional member as just another type of spring, and it would only be a preference for a type of spring that would lead a POSITA to choose a torsional member.

[240] It is clear that the three people who have training equivalent to the POSITA (i.e., Dr. Wooley, Skoczylas, and Tessier) all conflated these different types of springs and transposed their nomenclature. Their evidence is a good indicator that the POSITA, at the relevant date, would have thought that the specification of a torsional member in claim 1 of the '734 Patent is just a mere preference of the inventor in terms of the type of spring to be used, but is not an inventive feature over the use of prior art springs in torque anchors.

[241] Claim 1 states that the jaw is biased by a spring, and that the choice of spring is a torsional member. If the inventor intended to clearly distinguish between a torsional spring and a torsional member, then reference would have been made to a torsional member only.

[242] Counsel for the API Parties argued that Dr. Wooley failed to provide compelling reasons for why the POSITA would combine elements of the '467 Patent and the Burton tools. He asserted that there is no specific evidence of the use of torsional springs in torque anchors. Further, he urged they stated that all of his testimony should be disregarded because the methodology of the 2014 C-FER Tests is an indicator that Dr. Wooley's was not acting as an impartial expert.

[243] Counsel for the Excalibre Parties submitted that adding a spring was obvious given the reliability issues of the closed-bore '467 TorqStopperTM torque anchor, and the prior sale and use of the retrofitted '467 TorqStopperTM torque anchor, which had a torsional spring. While I was troubled with certain aspects of Dr. Wooley's report and testimony, I do agree with him that a POSITA would consider a torsional member to be simply the preferred variant of a torsional spring. The inventive concept in claim 1 of the '734 Patent is the addition of a spring to bias the jaw.

[244] I find that there was sufficient evidence adduced at trial to determine that torsional springs were a known biasing mechanism in downhole tools at the relevant date. Based upon the common general knowledge of the POSITA, at the relevant time, which I determined above included the '834 Burton Patent and the public use of the spring retrofitted, closed-bore '467 TorqStopperTM torque anchor, I find that the alleged inventive step of adding a torsional member or torsional spring in claim 1 of the '734 Patent would have been obvious to a POSITA. At best, the addition of the torsional spring was a workshop improvement. Therefore, I find that claim 1 of '734 Patent is invalid because of obviousness.

[245] In his report, Dr. Wooley asserted that if claim 1 of the '734 Patent is obvious, then all of the dependent claims are obvious. This is incorrect. Obviousness must be assessed claim by claim. As discussed above, Dr. Wooley tried to change his opinion at trial and amend his expert report, which was not permitted. During direct examination, he testified that all the dependent claims are obvious, and I give this testimony no weight because it was an opinion outside of what is in his expert report and not based on any independent analysis from his report.

[246] Although the API Parties submitted that none of dependent claims 2 to 15 of the '734 Patent are obvious, they neither asserted nor led evidence to show that any addition or combination of features disclosed in these claims disclose inventive steps additional to the spring in claim 1. In the absence of further inventive steps, the sale and prior public use of the spring retrofitted, closed-bore '467 TorqStopperTM torque anchor, I find that the features in these dependent claims would have been obvious to a POSITA at the relevant time.

[247] Tessier's testimony at trial suggested that the jaw and hinge on the retrofitted, closed-bore version of the '467 TorqStopperTM torque anchor was slightly different from the '734 TorqStopperTM torque anchor. However, he never indicated that the differences in the jaw or hinge were non-obvious changes beyond what would be necessary to accommodate a spring feature into the design of the tool. Therefore, the prior use of the spring retrofitted, closed-bore '467 TorqStopperTM torque anchor shows that, on a balance of probabilities, these claims are obvious.

[248] Independent claim 16 of the '734 Patent discloses an improvement to an anti-rotation tool that has a housing and at least one jaw, where the improvement is a torsional member that biases the jaw outward from the housing. Claim 16 discloses a torsional member only. However, based on the analysis of the terms spring and torsional member in claim 1, I find that claim 16 is also obvious because of the conflation between a torsional spring and a torsional member. The language of dependent claim 17—which discloses a torsional member, wherein the torsional members is a linearly extending member—and the principle of claim differentiation support this conclusion.

[249] Finally, dependent claims 17 to 19 are obvious for the same reason that claims 2 to 15 are obvious. Therefore, I find the '734 Patent claims to be invalid because of obviousness.

XV. The '026 Patent

A. *Utility*

[250] It is settled law that utility must be assessed on a claim by claim basis (*Astrazeneca Canada Inc v Apotex Inc*, 2015 FCA 158 at para 4).

[251] The Excalibre Parties argued that claim 1 of the '026 Patent is invalid because it does not disclose a useful invention since it fails to recite a means, such as the “inertial response” of “upon rotation” in the '467 Patent, to actuate the jaw. Therefore, they submitted that the tool recited in claim 1 is inoperable and invalid for inutility because it is broader than any invention made/disclosed and because the tool disclosed in claim 1 would do nothing when downhole.

[252] Counsel for the API Parties submitted case law for the proposition that a claim does not need to disclose everything necessary for the invention to work, as long as the missing element is a basic part of the common general knowledge (see *Canadian Patent Scaffolding Co v Delzotto Enterprises Ltd* (1979), 42 CPR (2d) 7 at para 23; *Astrazeneca 2015*, above, at para 281; *Burton Parsons Chemicals Inc v Hewlett-Packard (Canada) Ltd*, [1976] 1 SCR 555 at paras 12 to 16; *Delp v Fresh Headies Internet Sales Ltd*, 2011 FC 1228 at paras 13 to 14).

[253] The API Parties made few submissions specifically on this issue. They took the position that claim 1 of the '026 Patent is neither inoperable nor lacking in utility for the same reasons that claims 1 to 17 of the '467 Patent are neither inoperable nor lacking in utility. These reasons are based upon the factual evidence presented by Van Metre and McGowan, and the lack of probative evidence from the 2014 C-FER Tests. As discussed above, I find Van Metre's and McGowan's evidence to be persuasive, and I find that the 2014 C-FER Test are of little probative value.

[254] However, I do not agree that the reasons for finding claims 1 to 17 of the '467 Patent operable and useful are relevant to the construction, utility and overbreadth issues with respect to claim 1 of the '026 Patent. Claim 1 of the '026 Patent discloses a jaw that is rotatable around a hinge, but does not disclose the means of initiating rotation. Lacking any means of actuating of the jaw, whether by inertia or a biasing spring, the claim is broader than any invention made or disclosed, given that the invention must have some specified actuating means for the jaw, as found in claims 2 to 7. An inventor or patentee cannot excuse inoperable claims to an invention or claim too broadly beyond the invention disclosed and hope to sustain validity of that claim—overly broad, poorly drafted claims cannot be encouraged or condoned.

[255] The material question is whether the utility was either demonstrated or soundly predicted based on the information and expertise available by the filing date (*Apotex Inc v Wellcome Foundation Ltd*, 2002 SCC 77 at para 56; *Teva Canada Ltd v Pfizer Canada Inc*, 2012 SCC 60 at para 39). That is, could a POSITA make the invention work through the application of “some basic knowledge or routine testing”? (*Astrazeneca 2015* at para 281).

[256] Although not expressly stated, the API Parties' position appears to be that it would have been obvious to a POSITA, because of the existence of the '467 Patent, to infer that rotation of the tool would be the basic knowledge to apply to make the invention work. Because of the actuating mechanism of the '467 TorqStopper™ torque anchor, it is clear that a POSITA would perform routine tests where he or she rotated the tool to actuate the jaw using inertia.

[257] However, the Excalibre Parties argued that claim 1 of the '026 Patent may be used for a closed-bore tool, since the jaw is not explicitly recited as being formed from the housing wall, and they state that this jaw may not actually actuate upon rotation. Tessier's testimony establishes that there were issues setting closed-bore '467 TorqStopper™ torque anchors, using rotation alone because the jaw was smaller than in the open bore version. Additionally, Dr. Sorem stated that the jaws of TX series TorqStopper™ torque anchors ('026 TorqStopper™ torque anchors), which were designed to have a spring, may have a low inertia response, which would render them inoperable without a spring.

[258] Further, the jaw of the TorqStopper™ TX5-3 torque anchor is much smaller than the jaw of the spring retrofitted, closed-bore '467 TorqStopper™ torque anchor, supporting the conclusion that a POSITA would not be able to make the tool disclosed by claim 1 of the '026 Patent work through routine testing. In this case, the only tests of the utility of the tool disclosed in claim 1 of the '026 Patent are the 2014 C-FER Tests, which were inconclusive at best. Neither these tests, nor the assertions of the API Parties provided an adequate basis for sound prediction of utility. Therefore, I find that a POSITA would not be able to make the invention disclosed in

claim 1 of the '026 Patent work through the application of “some basic knowledge or routine testing”.

[259] Much has been written by our Courts about the POSITA, common general knowledge, and reading claims with a “mind willing to understand”, in order to find utility in what otherwise could be a deficient claim. However, there are no actuating mechanisms suggested by the API Parties that would save claim 1 of the '026 Patent from invalidity because of inutility. Claim 1 discloses an incomplete structure. An inventor or patentee cannot properly ask the Court to impart functional language into an overly broad claim, or a claim lacking utility, to try to correct poor drafting and in order to give the claim the necessary scope to be useful and not overly broad. To argue that this is permissible to support “a mind willing to understand” and give a purposive construction in the eyes of a POSITA, is stretching these concepts too far. One only has to look at claim 2 to see how this defective claim should have been and is cured.

B. *Anticipation*

[260] The '834 Burton Patent does not anticipate any of claims 1 to 7 of the '026 Patent for the same reasons that it does not anticipate any of claims 1 to 19 of the '734 Patent.

C. *Obviousness*

[261] The experts agreed that the allegedly inventive concept in the '026 Patent is the addition of the '026 Stop in claim 1. As discussed above, the experts disagreed as to whether the '026

Stop is distinct and different from the Hinge Stop, and whether the fact that the Hinge Stop is part of the prior art makes the '026 Stop obvious.

[262] Properly construed, the “first stop” is any component formed on the base of the jaw that cooperates with the “second stop”, which is any component on the housing, to limit the rotation of the jaw and to strengthen the jaw against torquing forces when the tool is up-hole. The '026 Stop is created by the cooperative engagement of these two stops.

[263] Counsel for the Excalibre Parties cited a number of patents that formed the common general knowledge at the relevant time—the '467 Patent, the '843 Burton Patent, and the '693 Aldridge Patent—which had Hinge Stops, consisting of two cooperating features that limited the rotation of a slip. Dr. Wooley stated that these Hinge Stops would have made the '026 Stop obvious to a POSITA at the relevant time. He also opined that because limiting rotation is the only function attributed to the '026 Stop in claim 1, a POSITA would have interpreted the “first stop” and “second stop” to be the two contact points that make up the Hinge Stop.

[264] Dr. Sorem stated that the '693 Aldridge Patent does not disclose a '026 Stop, because the sides of the slips and the sloped sides of the recesses, into which the slips are seated, are not equivalent to the “first stop” and “second stop”. In particular, Dr. Sorem focused on the fact that the '026 Stop improves the strength of the jaw and allows it to withstand greater torquing forces. He concluded that—given the information made available by the '467 Patent and its public uses, the '834 Patent and its public uses, and the '693 Aldridge Patent and its public uses—claim 1 of the '026 Patent is not obvious.

[265] Because of his construction of the terms “first stop” and “second stop”, Dr. Wooley did not address the existence of the strengthening feature of the ‘026 Stop’s strengthening feature in the prior art. In fact, it is clear that the Hinge Stop of the ‘467 TorqStopperTM torque anchor does not strengthen the jaw against torquing forces when the tool is up-hole. Therefore, the Excalibre Parties have not met the evidentiary burden to prove, on a balance of probabilities, that claim 1 of the ‘026 Patent is obvious.

[266] Claims 2 to 7 of the ‘026 Patent are dependent on claim 1. Therefore, given that claim 1 is not obvious, claims 2 to 7 are not obvious as well.

D. *Infringement*

[267] Even if I am incorrect about my determination that the ‘026 Patent is invalid because claim 1 is overbroad, I find that no version of the CTA Torque Anchor infringes any of the claims of the ‘026 Patent.

[268] The experts agreed that the ‘026 Patent has one independent claim, claim 1, which is similar to claim 1 of the ‘467 Patent (see above) and adds disclosure of the ‘026 Stop.

[269] Skoczylas opined that the inventive concept in the ‘026 Patent is not a new invention, but rather a workshop improvement over the invention disclosed by the ‘467 Patent. Specifically, he noted that the ‘026 Patent states that the “stops” are “radially spaced sufficiently so as to be inoperative in service...” meaning that the ‘026 Stop has no effect under downhole operation. He

opined that the purpose of '026 Stop is merely to prevent damage due to improper handling at the surface; therefore, not an essential element to the primary operation of the tool.

[270] Dr. Sorem opined that the '026 Stop is essential to both increase the ability of the jaw to withstand a torqueing force and prevent over-rotation of the jaw. In his opinion, this feature is an essential element of the '026 Patent that would fundamentally change how the '026 TorqStopper™ torque anchor functioned up-hole.

[271] There was no dispute that the '026 Stop is not engaged when the tool is downhole. However, it does make it easier for operators to thread the '026 TorqStopper™ torque anchor onto both the PC Pump and the production tubing. The Excalibre Parties presented no evidence showing that the '026 Stop is non-essential for this up-hole function.

[272] I find that the essential elements of the '026 Patent are as follows:

- a. a tubular housing;
- b. a wall of the housing that engages the casing (i.e., a casing-engaging wall);
- c. a jaw, with a radial tip that is rotatable around a hinge that is opposite the casing-engaging wall and that varies the effective diameter of the tool; and
- d. a first stop formed on the base of the jaw and a second stop formed on the housing, distinct from the hinge limit, that cooperate to prevent rotation of the jaw and strengthen the jaw against a torqueing force.

[273] Dr. Sorem's position was that the mounting blocks on versions 3 to 6 of the CTA Torque Anchor are functionally equivalent to the '026 Stop and, therefore, CTA Torque Anchor versions 3 to 6 infringe the '026 Patent. In his report he stated "the stops on the mounting blocks would perform substantially the same function downhole in substantially the same way ..." At trial, he amended this statement, striking the word downhole. However, he did not address whether the stop created by the mounting blocks strengthens the moveable slip against a torquing force when the tool is up-hole. Therefore, I give little weight to his testimony on this issue.

[274] Skoczylas testified that the stop feature on the jaw of all versions the CTA Torque Anchor is not on the base of the jaw, but on the side of the jaw. Therefore, the CTA Torque Anchors do not contain all the essential elements of any of the claims of the '026 Patent. On cross-examination, Skoczylas admitted that he only examined a physical example of version 6 of the CTA Torque Anchor, and was drawing his conclusions about the other versions from the diagrams provided by the Excalibre Parties. However, although versions 1A/B and 2A/B each have different stop features, versions 3 to 6 of the CTA Torque Anchor all have the same stop feature, which is found on the mount blocks. Regardless, I find that Skoczylas' evidence is of limited value on the issue of infringement because he did not perform an analysis of the stop features in versions 1A/B and 2A/B of the CTA Torque Anchor.

[275] Having considered the elements of all versions of the CTA Torque Anchor, I find that no version of the CTA Torque Anchor infringes claim 1 of the '026 Patent. As discussed for the '467 Patent, there is no version of the CTA Torque Anchor that has a casing-engaging wall. Further, there is no evidence showing that any version of the CTA Torque Anchor has the '026

Stop; however, this is not determinative to my finding of non-infringement. I also find that because claim 1 is not infringed, claim 2 cannot be infringed.

XVI. Section 7(a) of the Trade-marks Act

[276] Sections 7(a) of the *Trade-marks Act* states:

Unfair Competition and prohibited Marks

Prohibitions

7 No person shall

(a) make a false or misleading statement tending to discredit the business, goods or services of a competitor;

...

Concurrence déloyale et marques interdites

Interdictions

7 Nul ne peut :

a) faire une déclaration fausse ou trompeuse tendant à discréditer l'entreprise, les produits ou les services

d'un concurrent;

...

[277] Section 53.2(1) of the *Trademarks Act* states:

Power of court to grant relief

53.2 (1) If a court is satisfied, on application of any interested person, that any act has been done contrary to this Act, the court may make any order that it considers appropriate in the circumstances, including an order providing for relief by way of injunction and the recovery of damages or profits, for punitive damages and for the destruction or other disposition of any offending goods, packaging, labels and advertising material and of any

Pouvoir du tribunal d'accorder une réparation

53.2 (1) Lorsqu'il est convaincu, sur demande de toute personne intéressée, qu'un acte a été accompli contrairement à la présente loi, le tribunal peut rendre les ordonnances qu'il juge indiquées, notamment pour réparation par voie d'injonction ou par recouvrement de dommages intérêts ou de profits, pour l'imposition de dommages punitifs, ou encore pour la disposition par destruction ou autrement des

equipment used to produce the goods,
packaging, labels or advertising
material.

produits, emballages, étiquettes et
matériel

publicitaire contrevenant à la
présente loi et de tout équipement
employé pour produire ceux-ci.

[278] The combined effect of these two sections “create a statutory cause of action for which damages may be awarded if a person is damaged by false or misleading statements by a competitor tending to discredit the claimant’s business, wares or services” (*S & S Industries Inc v Rowell*, [1966] SCR 419 at 424 [*S&S*]). The essential elements required to establish a claim under section 7(a) of the *Trade-marks Act* are set out by the Supreme Court of Canada in *S&S*, above, at 424, namely that there must be established in evidence:

- a. a false and misleading statement;
- b. tending to discredit the business, wares or services of a competitor; and
- c. resulting damages.

[279] What constitutes a false and misleading statement will depend on the circumstances of the assertions and the conduct of the parties making the assertions. It is, however, settled law that there is no requirement that the party making the false or misleading statements does so with knowledge of their falsity or with malice (*S&S*, at 425).

[280] In this case, because I find that that no version of the CTA Torque Anchor infringes any of the API Patents, it is clear that Goodwin’s letters to Husky and Bronco (i.e., the January 16, 2008 Husky Letter; the February 1, 2008 Husky Letter; the April 28, 2008 Husky Letter; and the May 16, 2008 Bronco Letter), sent on behalf of API, contained false and misleading statements.

Further, the January 16, 2008 Husky Letter and the May 16, 2008 Bronco Letter both strongly suggest that Excalibre's CTA Torque Anchors infringe the '734 Patent, in addition to the '467 and '026 Patents. The API Parties never pleaded that there was infringement of the '734 Patent in their action before this Court.

[281] Section 43(2) of the *Patent Act* states that issued patents are presumed valid, absent evidence to the contrary. Patentees are entitled to assert that they have rights flowing from a valid patent. Therefore, not every assertion of a patent or other intellectual property, which may subsequently be held to be invalid, will be held to constitute a false and misleading statement per section 7(a) (*E Mishan & Sons, Inc v Supertek Canada Inc*, 2016 FC 986 [*Supertek*] at para 11).

[282] It is important to distinguish between cease and desist letters that are informative and letters that are threatening. In *Supertek*, above, Mr. Justice Roger Hughes contrasted the situation in *S&S*, where the false and misleading statements consisted of a cease and desist letter threatening litigation that never came to pass, with the situation in *M&I Door Systems Ltd v Indoro Industrial Door Co Ltd* (1989), 25 CPR (3d) 477 (FCTD), where the cease and desist letter was more informative than threatening. Informative letters set out a patentee's rights and provide information that will enable the recipient to understand what may constitute infringement. Threatening letters contain explicit or veiled threats that the recipient will be sued if they do not change a particular course of conduct.

[283] Statements made in a threatening cease and desist letter will tend to discredit the goods or services of the patentee's competitor. In *Supertek*, at paragraph 27, Mr. Justice Hughes found

that E. Mishan & Sons had made false and misleading statements tending to discredit the goods of *Supertek* in the course of negotiations with Canadian Tire, which gave Canadian Tire the impression that they would be sued for patent infringement if they stocked Supertek's product, even though the patent had been held to be invalid in other proceedings.

[284] From the plain text of Goodwin's letters, it is clear that all of the letters to Husky and the letter to Bronco are threatening and discredit Excalibre's CTA Torque Anchors. The January 16, 2008 Husky Letter and February 1, 2008 Husky Letter state that API has been credibly informed that Husky is choosing to source a product other than the TorqStopperTM torque anchors, strongly imply that this other product infringes API's patent rights, and inform Husky that API aggressively protects its intellectual property rights through litigation. The April 28, 2008 Husky Letter and the May 16, 2008 Bronco Letter contain explicit threats of litigation should Husky and/or Bronco continue sourcing the Excalibre CTA Torque Anchors:

(April 28, 2008 Husky Letter)

API demands Husky immediately cease sourcing the CTA torque anchor. Husky is encouraged to review the attached SOC and assess their own liability in this infringement of API's exclusive rights. ... Should Husky choose to continue along their current path, API will be compelled to amend their litigation to include Husky.

(May 16, 2008 Bronco Letter)

The Canadian Patent Act also provides API with similar right [*sic*] of enforcement against purchasers and as against users of patented torque anchors which are not obtained from authorized sources, including Bronco Energy. ... Unless Bronco Energy advises this office, by May 23rd, of their immediate cessation of the above infringing activities, API will amend their litigation to include Bronco Energy.

[285] It is settled law that evidence of actual or potential damage is a necessary element for finding liability under section 7. In *BMW Canada Inc v Nissan Canada Inc*, 2007 FCA 2007 at paragraph 35, Chief Justice John D. Richard stated:

Without commenting on the first two elements, I find the trial judge erred in law in assuming that there would be damages. Actual or potential damage is a necessary element in finding liability under paragraph 7(b). In the absence of evidence in this regard, the Court cannot conclude that there is liability.

[286] This statement about the necessity of evidence proving damages has been extended to the analysis under 7(a) (see *Uview Ultraviolet Systems Inc v Brasscorp Ltd*, 2009 FC 58 at para 240). Additionally, there must be evidence proving “a causal link between the wrongful activity in uttering false and misleading statements and the alleged damage suffered” (*Supertek* at para 29). As with tort actions, the plaintiff bears the burden of proving causation.

[287] An order bifurcating the issue of damages was issued in these proceedings. The Excalibre Parties, therefore, did not present any invoices or business records showing how the letters to Husky or Bronco resulted in damage to their business. However, three fact witnesses—Esposito for Bronco, and Wichmann Cohen and Redhead for Husky—testified that the contents of the letters did, in fact, change their companies’ purchasing decisions regarding CTA Torque Anchors, which culminated in their decisions to no longer purchase CTA Torque Anchors from their suppliers. There is an indisputable nexus arising between the impugned letters and resulting loss of business and damage, even if unquantified, to the Excalibre Parties.

[288] I find the testimony of all three witnesses credible. Both Redhead and Wichmann Cohen were subpoenaed to testify, and neither of them have any interest in the outcome of this trial.

Further, the oral testimony of the Husky witnesses is supported by emails, which explicate how the events unfolded.

[289] Therefore, I find that there is evidence establishing that the damage to the Excalibre Parties' business due to Bronco's and Husky's decisions to cease sourcing CTA Torque Anchors was caused by the false and misleading statements made in Goodwin's letters. The quantum of damage is left to be determined by a reference after trial.

[290] However, the Excalibre Parties also argued that resulting damage includes any cessation in sale of other Excalibre products to customers beyond the CTA Torque Anchors. I do not accept this argument, as there is no evidence to support this position and, in any event, it is far too remote to be sustainable on any reasonable basis. Nor do I find any evidence that would warrant finding Tessier, Weber, or Doyle liable for the letters sent on behalf of API. There is no evidence to support a finding that any of these individuals acted outside their duties and responsibilities as officers or directors of API. Accordingly, only API is liable for any damages arising from the contravention of section 7(a) by reason of the Goodwin Letters being sent to Excalibre's customers.

[291] Additionally, although Moore testified, and Wichmann Cohen corroborated, that Excalibre tried to mitigate its losses with regards to sales of the CTA Torque Anchor to Husky, there was no evidence presented at trial showing that Excalibre took any action to otherwise lessen the damage caused by Goodwin's letters. It is not clear that Excalibre would not have been able to conduct business with other companies in the years between the delivery of the

letters (in 2008) and this trial, specifically with regards to their non-torque anchor products. Further, there is no argument or evidence explaining why Kudu, Carder, and Logan, as suppliers with access to different brands of torque anchors, could not have taken steps to mitigate their losses with respect to Husky and Bronco.

XVII. Remedies

[292] Given the findings on validity and infringement, the API Parties are not entitled to any of the relief sought in their Statement of Claim.

[293] The Excalibre Parties are entitled to damages from API only resulting from the misleading statements made pursuant to section 7(a) of the *Trade-marks Act*, the quantum of which is to be determined by way of reference after trial.

[294] The Excalibre Parties are also entitled to a permanent injunction restraining API from making representations to third parties, including customers and potential customers of the Excalibre Parties, that versions 1 to 6 of the CTA Torque Anchor infringe the claims of the API Patents.

XVIII. Costs

[295] Given the relative success of the Excalibre Parties in defending the action brought by API and in prosecuting their counter-claim, absent any previous and more favourable offer of settlement or other mitigating factors, I see no reason why costs should not follow the event.

[296] However, the Excalibre Parties attempted to amend their pleadings at trial with no reasonable basis for the delay in doing so. Moreover, they raised unwarranted objections during the trial which caused needless delay. These tactics will not be condoned by the Court. Accordingly, any costs to be awarded to the Excalibre Parties shall be reduced by a factor of twenty-five percent (25%).

[297] The parties may make submissions on costs to the Court within two weeks of the date of this judgment.

[298] A copy of this judgment and reasons shall be placed on each of Court files T-1741-08 and T-1946-09.

JUDGMENT

THIS COURT'S JUDGMENT is that:

1. The API Patents were validly assigned to Lynn Tessier, John Doyle, and James Weber.
2. The '467 Patent is valid; however, none of claims 1 to 9 or 12 to 17 are infringed by any version of the CTA Torque Anchor.
3. The '734 Patent is invalid because claims 1 to 19 are obvious.
4. Claim 1 of the '026 Patent is invalid for inutility, because claim 1 is broader than the scope of the invention disclosed or made. Claims 2 to 7 are valid; however, claims 2 to 7 are not infringed by any version of the CTA Torque Anchor.
5. API made false or misleading statements tending to discredit the business, wares, or services of the Excalibre Parties, which caused damage to the business of the Excalibre Parties, contrary to section 7(a) of the *Trade-marks Act*.
6. Given the findings on validity and infringement, the API Parties are not entitled to any of the relief sought. The Excalibre Parties are entitled to damages from API resulting from the misleading statements made pursuant to section 7(a) of the *Trade-marks Act*, to be determined in a reference after trial, and an injunction restraining API by its officers, directors or persons under its control from making representations to third parties, including customers and potential customers of the Excalibre Parties, that versions 1 to 6 of the CTA Torque Anchor infringe the claims of the API Patents.
7. Costs of the proceedings are left to the parties to resolve. If the parties cannot agree on a costs disposition, concise written cost submissions, not exceeding 5 pages in length, shall be submitted no later than 14 days of the date of this Judgment.

"Michael D. Manson"

Judge

FEDERAL COURT
SOLICITORS OF RECORD

DOCKET: T-1741-08

STYLE OF CAUSE: EXCALIBRE OIL TOOLS LTD ET AL V ADVANTAGE PRODUCTS INC ET AL

PLACE OF HEARING: CALGARY, ALBERTA

DATE OF HEARING: SEPTEMBER 12, 2016 TO SEPTEMBER 16, 2016
SEPTEMBER 19, 2016 TO SEPTEMBER 26, 2016
OCTOBER 3, 2016

JUDGMENT AND REASONS: MANSON J.

DATED: NOVEMBER 17, 2016

APPEARANCES:

Mr. Doak Horne FOR THE PLAINTIFFS
Mr. Shaun Cody

Mr. Christopher Kvas FOR THE DEFENDANTS
Mr. William Regan
Mr. Dominic Venturo

SOLICITORS OF RECORD:

GOWLING WLG FOR THE PLAINTIFFS
Calgary, Alberta

NEW HORIZON LAW FOR THE PLAINTIFFS
Calgary, Alberta

PIASETZKI NENNIGER KVAS LLP FOR THE DEFENDANTS
Toronto, Ontario

FEDERAL COURT
SOLICITORS OF RECORD

DOCKET: T-1946-09

STYLE OF CAUSE: ADVANTAGE PRODUCTS INC ET AL V EXCALIBRE
OIL TOOLS LTD ET AL

PLACE OF HEARING: CALGARY, ALBERTA

DATE OF HEARING: SEPTEMBER 12, 2016 TO SEPTEMBER 16, 2016
SEPTEMBER 19, 2016 TO SEPTEMBER 26, 2016
OCTOBER 3, 2016

JUDGMENT AND REASONS: MANSON J.

DATED: NOVEMBER 17, 2016

APPEARANCES:

Mr. Christopher Kvas
Mr. William Regan
Mr. Dominic Venturo

FOR THE PLAINTIFFS

Mr. Doak Horne
Mr. Shaun Cody

FOR THE DEFENDANTS

SOLICITORS OF RECORD:

PIASETZKI NENNIGER KVAS LLP
Toronto, Ontario

FOR THE PLAINTIFFS

GOWLING WLG
Calgary, Alberta

FOR THE DEFENDANTS

NEW HORIZON LAW
Calgary, Alberta

FOR THE DEFENDANTS