

Federal Court



Cour fédérale

Date: 20160316

Docket: T-496-11

Citation: 2016 FC 320

Ottawa, Ontario, March 16, 2016

PRESENT: The Honourable Mr. Justice Manson

BETWEEN:

UPONOR AB

Plaintiff

And

**HEATLINK GROUP INC. AND PEXCOR
MANUFACTURING COMPANY INC. AND
CROSSLINK FINLAND OY AND INOEX
GMBH AND INOEX LLC**

Defendants

AND BETWEEN:

**PEXCOR MANUFACTURING COMPANY
INC. AND HEATLINK GROUP INC.**

Plaintiffs by Counterclaim

And

UPONOR AB

Defendant by Counterclaim

TABLE OF CONTENTS

I.	Background	3
A.	The Parties and Pleadings	3
B.	Technical and Background Information to Understanding the '376 Patent	6
(a)	Polyethylenes & Crosslinking.....	6
(b)	Infrared Radiation, Equipment & Spectra.....	8
II.	Canadian Patent 2,232,376 (the '376 Patent)	8
A.	Claims in Issue: 1-38 (Counterclaim relates to validity of all the Claims).....	8
B.	Claim Construction	9
(a)	Principles, Relevant Date	12
(b)	Claim Terms Needing Construction	13
(i)	Elimination.....	14
(ii)	Filtered out	14
(iii)	Wavelengths corresponding to the absorption peaks of polymer material.....	15
(c)	The Person Skilled in the Art (POSITA)	15
(d)	Common General Knowledge.....	16
III.	Preliminary Issues.....	18
A.	Relevant Dates for Anticipation, Obviousness: claim date (priority documents)	18
B.	Inventors' Liability under Section 53 of the Patent Act	19
IV.	Fact Witness Evidence.....	21
A.	Bill Gray.....	21
B.	David Harget.....	22
C.	Jan Rydberg.....	22
D.	Michael Sjöberg	23
E.	Jan Robertson.....	23
V.	Expert Witness Evidence on Claim Construction and Validity.....	24
A.	Plaintiff's Expert Witnesses.....	24
(1)	Dr. Gene Palermo	24
(2)	Dr. Robert Kimmel	27
B.	Defendants' Expert Witnesses	35
(1)	Dr. Glenn Boreman.....	35
(2)	Dr. John Dutcher.....	39
(3)	Franz Seydel	42
C.	Plaintiff's Responding Reports on Validity	45
(1)	Dr. Robert Kimmel	45
(2)	Dr. Mohamad Al-Sheikhly	46
VI.	Validity Analysis	47

A.	Unpatentable Subject Matter.....	47
B.	Utility	48
C.	Insufficiency of the Disclosure	52
D.	Anticipation.....	61
	(1) The IR Handbook	63
	(2) Electric IR Heating	66
	(3) Polymer Processing	66
	(4) The ‘624 Patent.....	67
E.	Obviousness	68
VII.	Expert Witness Evidence on Infringement	78
A.	Plaintiff’s Expert Witnesses.....	78
	(1) Dr. Gene Palermo	78
	(2) Dr. Robert Kimmel	80
B.	Defendants’ Expert Witnesses	80
VIII.	Infringement Analysis.....	81
A.	Pexcor.....	81
B.	Heatlink.....	82
C.	Crosslink	82
	(1) Direct	82
	(2) Indirect (Inducing)	83
D.	Laches and Acquiescence	88
E.	Unclean Hands	89
IX.	Remedies.....	89

JUDGMENT AND REASONS

I. Background

A. *The Parties and Pleadings*

[1] This action concerns the infringement and validity of a number of claims of Canadian Patent 2,232,376 [the ‘376 Patent].

[2] The ‘376 Patent, entitled “Method for Heating and/or Cross-Linking of Polymers and Apparatus Therefor”, relates in general terms to a uniform, fast, and contactless method of crosslinking polymers using infrared [IR] radiation, wherein the wavelengths corresponding to

absorption peaks for the polymer material are eliminated in the IR radiation. The invention also relates to an apparatus used for the polymer crosslinking.

[3] The '376 Patent was assigned a filing date of September 20, 1996, by the Canadian Intellectual Property Office, was published on March 27, 1997, and was issued on November 19, 2002. It claims priority from three foreign applications; 9503272-8 (Sweden), filed September 20, 1985; 9600091-4 (Sweden), filed January 11, 1996; PCT/EP96/02801 (PCT), filed June 26, 1996. The '376 Patent continues to be in good standing.

[4] The Plaintiff in this action is a Swedish company, Uponor AB [Uponor], who is owner of the '376 Patent. Wirsbo Bruks AB [Wirsbo], a predecessor company to Uponor, was the first company to manufacture crosslinked polyethylene [PEX] pipes. PEX has significant product performance advantages over non-crosslinked polyethylene pipes, and is also highly marketable by virtue of it being less expensive and quicker to install than non-crosslinked polyethylene.

[5] The Defendants Pexcor Manufacturing Inc. [Pexcor] and Heatlink Group Inc. [Heatlink] are affiliated companies based in Calgary, Alberta that manufacture and sell PEX pipe. Garry Schmidt and Manfred Schmidt are the key executives for management and operations of Pexcor and Heatlink. The third Defendant, Crosslink Finland OY [Crosslink], is a Finnish company that supplies, operates, imports, services and provides support for the IR ovens used by Pexcor. Mr. Aarne Heino is the principal and sole operator of Crosslink.

[6] Uponor claims that the Defendants Pexcor, Heatlink and Crosslink have infringed certain process claims (claims 1, 2, 3, 4, 7, 8, 9, 11, 12, 13, 14, 15, 16, 17) and apparatus claims (claims 19, 22, 23, 24, 25, 26, 27, 29, 30, 32, 33, 34, 35, 36, 37, 38) of the '376 Patent.

[7] Between 2000 and 2012, Crosslink supplied Pexcor with six IR radiation ovens. Using the ovens, Pexcor started commercial manufacture of PEX pipe in 2003. Uponor asserts that Pexcor is unauthorized to use the patented process and apparatus in the '376 Patent to make PEX pipe, and thereby directly infringed the patent.

[8] Uponor asserts Heatlink is also liable for infringing the '376 Patent, as Heatlink markets, sells and distributes PEX pipe manufactured by Pexcor's infringing process.

[9] Crosslink's subcontractor attended Pexcor's facilities in Alberta, Canada, between 2005 and 2012 to add more IR units to the crosslinking ovens. Uponor claims that Crosslink's reconstruction of the '376 patented apparatus for Pexcor's use in the '376 patented process renders Crosslink liable for direct infringement for having "made" the ovens in Canada.

[10] Uponor also alleges Crosslink induced infringement of the '376 Patent. They claim that "but-for" Crosslink's activities, Pexcor would not have directly infringed the patent's process and apparatus claims. Crosslink provided Pexcor with instructions, advice, services, warranties and training, which enabled Pexcor to achieve the desired crosslinking of polyethylene by using the '376 Patent process. Uponor claims this infringement was knowingly induced by Mr. Heino of Crosslink.

[11] The Defendants denied all allegations of infringement and counterclaimed, challenging the validity of all 50 claims of the '376 Patent on the basis of anticipation and obviousness, insufficiency of description and indistinct claims, lack of utility, overbreadth, unpatentable subject matter and non-entitlement to priority claims. They also alleged the '376 Patent is void under section 53(1) of the *Patent Act*, RSC 1985, c P-4, on the basis that untrue material allegations were wilfully made for the purpose of misleading during the prosecution of the '376 Patent.

[12] Pexcor and Heatlink also allege Uponor is guilty of laches and acquiescence in bringing the action, as Uponor knew or ought to have known that manufacture by Pexcor and sale by Heatlink commenced in 2003. Uponor formed the belief the '376 Patent was being infringed in 2005, yet did nothing to raise allegations of infringement until commencement of this action in January 2011.

B. *Technical and Background Information to Understanding the '376 Patent*

[13] The experts provided technical and background information they considered important for understanding the '376 Patent in context, and which they find would have been known by a person of skill in the art [POSITA] at the relevant time.

(a) *Polyethylenes & Crosslinking*

[14] Polyethylenes are repeating units of two carbons and four hydrogens. They have diverse applications by virtue of their good thermal insulating properties, tensile strength, and relatively low melting points. The type of polyethylene used for a given application depends on how their

repeating units are arranged. High density polyethylene [HDPE] is used in pipe manufacture, and is characterized by a high number of densely-packed polyethylene chains that form crystalline structures resulting in greater stiffness, strength and superior barrier properties.

[15] Crosslinking of polyethylene causes bond formation between adjacent polymer chains, which restricts the movement of chains relative to each other, resulting in increased strength, chemical, and heat resistance as compared to un-crosslinked polyethylene.

[16] There are several ways to crosslink polyethylene. The '376 Patent specification states the process taught in the patent is faster and provides superior quality products than previously widely-used polyethylene crosslinking processes: the Engel method and PEXEP Process.

[17] The Engel method, developed in the early 1970's, involves mixing polyethylene resin pellets with organic peroxides prior to heating and extrusion. The '376 Patent varies this method by using IR radiation as the heat source.

[18] In the PEXEP process, an extruded tube of polyethylene is heated by direct contact with heated wheels in order to initiate crosslinking. The background description of the '376 Patent invention states the disadvantages of the PEXEP process are reduced dimensional stability, inferior surface quality and non-uniform crosslinking throughout the entire tube wall.

(b) *Infrared Radiation, Equipment & Spectra*

[19] IR radiation is a type of electromagnetic radiation. It is used in a wide variety of industrial equipment to heat, cure or dry products. Such equipment usually permits temperature regulation of the IR-generating source, which correlatively adjusts the desired wavelengths transmitted. IR radiation follows a characteristic distribution of wavelengths: shorter wavelengths [short-wave IR] are emitted at higher temperatures and longer wavelengths [long-wave IR] are emitted at lower temperatures.

[20] A material's molecular structure causes it to better absorb different wavelengths of IR radiation, referred to as a material's absorption profile. The IR spectrum for a given material, measured using IR spectroscopy, can be shown as a plot of either absorbance or transmittance versus wavelength. Polyethylene optimally absorbs IR radiation at 3.2 to 3.6 microns [μm], 6.6 to 6.8 μm (the absorption peaks).

II. Canadian Patent 2,232,376 (the '376 Patent)

A. *Claims in Issue: 1-38 (Counterclaim relates to validity of all the Claims)*

[21] A short description of the alleged inventive concept of the '376 Patent is set out in pages 4 to 5 of the specification:

The object of the present invention is to set forth a process and an apparatus making possible a fast, contactless and uniform heating of a polymer or polymer mix (which in the following will be called polymer material), inter alia for cross-linking, so that manufacture of objects made of cross-linkable polymers can be carried out at high speeds and with a good surface finish.

In accordance with the invention this is achieved in that the polymer material is irradiated with infrared radiation having wave lengths which differ from the wave lengths which are absorbed by

the polymer material in question. This means that the infrared radiation penetrates through the polymer and in this way quickly heats the moulding throughout its entire thickness. In cross-linking this means that a high speed of manufacture is made possible. Since the heating is carried out by means of infrared radiation the heating can be done entirely without contact, which results in a high surface finish. In a preferred embodiment, primarily used for cross-linking after extrusion, the zone with infrared radiation is arranged in a vertical direction from the extrusion nozzle, preferably upwardly, so that the moulding after the extrusion is fed vertically upwards through the said zone. Because of the fast and uniform heating the cross-linking proceeds quickly and the extruded moulding rapidly retains a high rigidity (that is the material in the body or moulding passes from having been mainly viscous to being mainly visco-elastic). Since the cross-linking zone at the same time can be made short this results in that the risk for deformation or local thickening due to vertical yielding caused by gravitational forces will be small. Both the dimensional and the thermal stability thus will be high. To the extent peroxide for instance is used as a cross-linking agent, the agent does not have time to evaporate from the surface.

The above-mentioned objects of the invention are also achieved by means of an apparatus for heating mouldings provided with at least one zone with at least one source of infrared radiation, particularly for cross-linking of polymers which are cross-linkable by means of heat, the infrared radiation having wave lengths that mainly differ from the absorption peaks of the polymer in question.

B. *Claim Construction*

[22] The two independent claims that are the focus of this action are claims 1 and 19:

a) Claim 1:

- Process for heating a polymer material, comprising irradiation of said polymer material with infrared radiation, wherein wave lengths corresponding to the absorption peaks for the polymer material in respect of infrared radiation, have been eliminated in the infrared radiation irradiating the polymer material.

b) Claim 19:

- Apparatus for heating polymer material, comprising at least one zone with at least one source of infrared radiation for Irradiation of the polymer material with infrared radiation in which the wave lengths corresponding to the absorption peaks of the polymer material in respect of infrared radiation have been eliminated.

[23] While claim 1 covers a process for heating a polymer material and claim 19 covers an apparatus for heating a polymer material, the essential features defining the invention claimed are the same:

- a) irradiation of the polymer material with IR radiation;
- b) such that the wavelengths corresponding to the absorption peaks for the polymer material in respect of the IR radiation have been eliminated.

[24] Claim 19 requires that the apparatus used have at least one zone with one source of the IR radiation.

[25] A useful diagram of an embodiment of the process covered by narrower claims is shown in Figure 1 of the '376 Patent (labelling added):

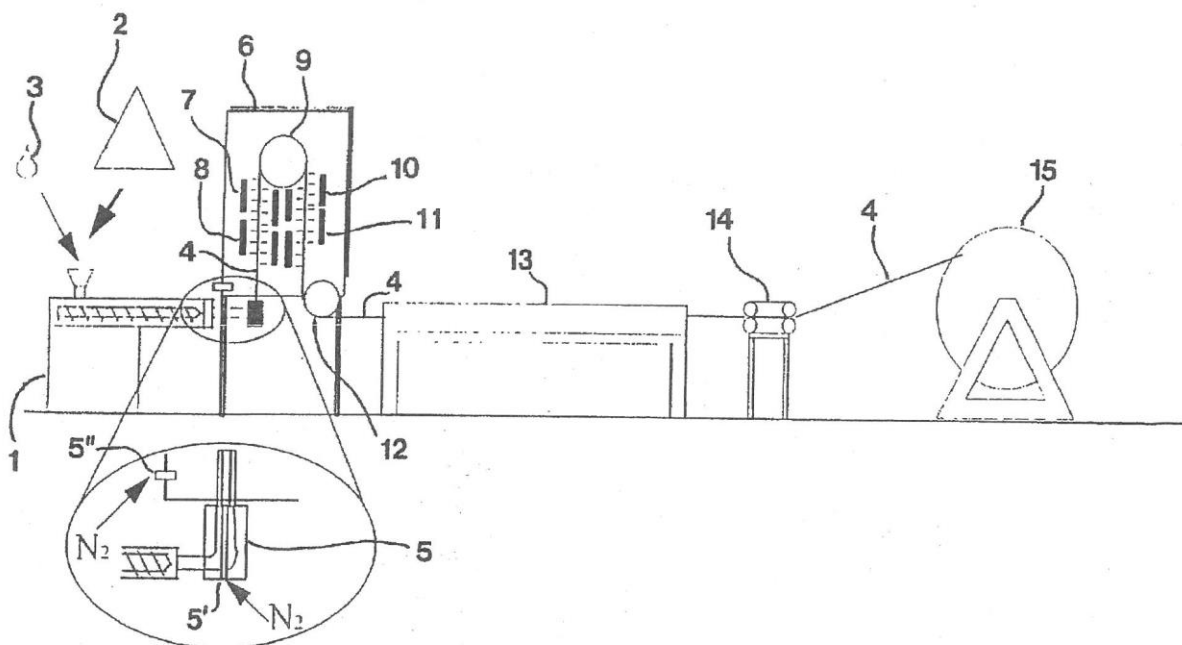

[26] The process, commencing at the left of the above diagram, is as follows: the peroxide (3) and polymer (2) are mixed in a hopper, and then enter the extruder. The extruded polymer pipe (4) then travels around a wheel and is directed 90° upwards through four IR zones (7, 8), it then

turns 180° over and around a large wheel at the top (9), and travels vertically downwards through a further four IR zones (10, 11). The pipe is then guided by another wheel (12) to make another 90° turn and enters a water bath (13) to cool and calibrate the pipe. Additional coatings are added, the pipe travels through a second water bath and is finally coiled, cut and bundled (15).

[27] Figure 4 of the '376 Patent depicts the IR absorption profile of polyethylene. The large dips (labelled A and B) portray polyethylene's main absorption peaks at 3.3 to 3.6 μm and 6.6 to 6.7 μm. It was the topic of much discussion at trial and is included herein for ease of reference:

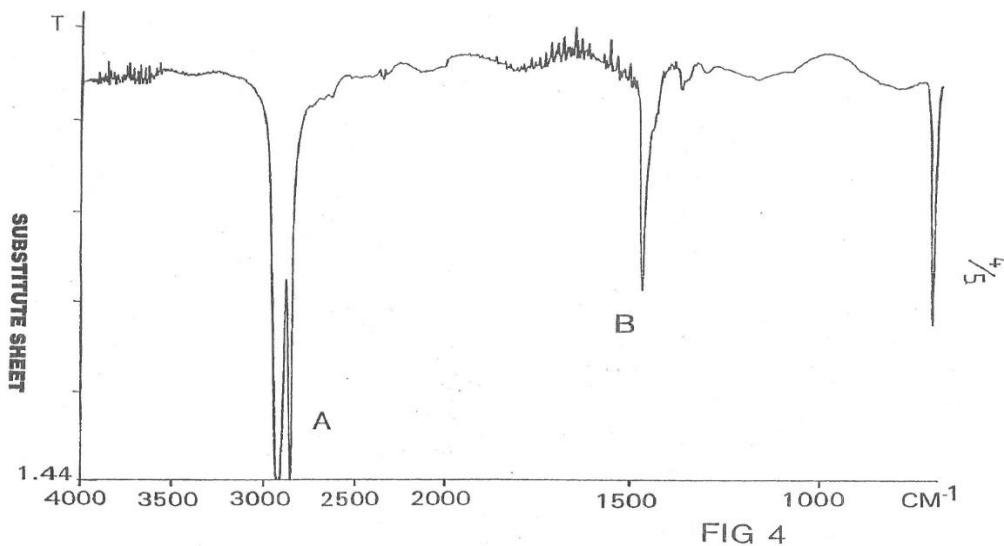

[28] While there are multiple claim dependencies, necessitating a claim by claim analysis for purposes of determining both the validity and infringement issues, the Expert Report of Dr. Kimmel on behalf of the Plaintiff provided a useful grouping of the general types of claims:

- a) Group A (claims 1, 4-7, 14, 18, 19, 24, 28, 29-32, 38, 47-50): relates to irradiating polymer material with IR radiation in which absorption peaks of the polymer material have been eliminated. Dr. Kimmel included in this group dependent claims describing additional subject matter for use in manufacturing, such as use of reflecting devices, use of inert gases such as nitrogen, and the manufacture of oriented pipe and composite pipes;
- b) Group B (claims 2, 3, 26, and 37): relates to elimination using filters;

- c) Group C (claims 33, 34): relates to elimination using IR lamps;
- d) Group D (claim 22): involves regulating IR radiation to achieve the desired degree of crosslinking;
- e) Group E (claims 8-13): relates to the use of polyethylene, organic peroxides or azo-compounds as crosslinking additives, and to specific wavelengths;
- f) Group F (claims 15-17, 23, 25-27, 35): relates to the continuous extrusion of pipe, fed vertically through IR zones;
- g) Group G (claims 20-21): relates to a transparent forming tool for shaping the polymer product;
- h) Group H (claims 39-46): relates to processes and products to recondition pipes.

[29] The Plaintiff of course argues that all of the claims asserted are valid and infringed.

However, if the Court is to find that independent claims 1 and 19 are invalid, the Plaintiff asserts that at least the claims relating to vertical orientation within the manufacturing process (some of the Group F claims above), although built up from multiple claim dependencies, are nevertheless valid and infringed.

(a) *Principles, Relevant Date*

[30] The relevant date for construing claims is the date of publication of the '376 application, March 27, 1997. Construction is a question of law for the Court and should be done before considering infringement or validity; the same issues of construction apply for both validity and infringement (*Pfizer Canada Inc v Canada (Minister of Health)*, 2005 FC 1725 at para 10, aff'd 2007 FCA 1).

[31] The parties agree that the canons of claim construction have been determined in the leading Supreme Court of Canada decisions of *Whirlpool Corp v Camco Inc*, 2000 SCC 67 at paras 49-55 [*Whirlpool*]; *Free World Trust v Électro Santé Inc*, 2000 SCC 66 at paras 44-54

[*Free World Trust*]; and *Consolboard Inc v MacMillan Bloedel (Saskatchewan) Ltd*, [1981] 1

SCR 504 at para 27 [*Consolboard*]. They are:

- a) Claims are to be read in an informed and purposive way with a mind willing to understand, viewed through the eyes of a POSITA as of the date of publication having regard to the common general knowledge;
- b) Adherence to the language of the claims allows them to be read in the manner the inventor is presumed to have intended and in a way that is sympathetic to accomplishing the inventor's purpose, which promotes both fairness and predictability;
- c) The whole of the specification should be considered to ascertain the nature of the invention, and the construction of claims must be neither benevolent nor harsh, but instead should be reasonable and fair to both the patentee and the public.

[32] While experts may aid the Court in construing terms or elements of the claims, that assistance is only necessary when the Court deems it helpful or useful to do so – if the meaning of terms is evident from the patent specification, the Court does not need the advice of experts.

(b) *Claim Terms Needing Construction*

[33] While there were a number of opinions expressed by the parties' experts on the meaning of terms used in the claims of the '376 Patent, as discussed below in reviewing the experts' evidence, the terms that introduce some question as their meaning are: (i) "elimination", as used in claims 1 and 19; (ii) "filtered out", as used in claims 2 and 3; and (iii) wavelengths corresponding to the absorption peaks of the polymer material.

[34] There was some divergence in opinion around "polymer material" and "filters", however, I do not find the experts' views necessary to help the Court define or construe these terms.

(i) Elimination

[35] Independent claims 1 and 19 refer to “elimination” of the wavelengths corresponding to the absorption peaks (also identified as “bands”) of polymer material.

[36] The experts all agreed that elimination does not mean complete elimination or the absence of any IR wavelengths corresponding to the absorption peaks of the polymer material being irradiated. Some absorption is necessary to sufficiently heat the polymer in order for crosslinking to occur. It is agreed that eliminated means that the IR radiation wavelengths corresponding to the absorption peaks of the polymer are substantially reduced. What constitutes a “substantial reduction” is not disclosed in the patent, is disputed, and is analyzed below.

(ii) Filtered out

[37] Claims 2 and 3 refer to the wavelengths corresponding to the absorption peaks for the polymer material being “filtered out”.

[38] The specification teaches two ways of achieving elimination of the wavelengths corresponding to the absorption peaks. One way is to place filters between the IR sources and the object being irradiated, such as polyethylene pipes. Filters work by either reflecting away the undesired wavelengths, or by absorbing them before they can reach the target surface. The ‘376 Patent’s examples of possible filters are silica glass (SiO₂), Pyrex or Crown glass.

[39] The other manner of eliminating wavelengths corresponding to a polymer’s absorption peaks is by using IR radiation having a wavelength substantially located at 1.2 μm.

[40] The parties' experts disagreed on what a POSITA of the '376 Patent would understand when reading the specification and the use of "filtered out" in claims 2 and 3. I find that the '376 Patent clearly specifies that using the four types of filters disclosed should enable a POSITA to achieve the elimination of wavelengths corresponding to the absorption peaks of polymer material – which simply is not the case. I will discuss this issue further below.

(iii) Wavelengths corresponding to the absorption peaks of polymer material

[41] A POSITA at the date of publication of the '376 Patent would understand from the specification that by referring to "absorption peaks" the inventors are concerned with the primary absorption peaks of polymers at about 3.2-3.6 μm and 6.6-6.8 μm .

[42] Defence expert, Dr. Dutcher, argued that absorption peaks at wavelengths around 1.5 to 1.7 μm are omitted from Figure 4 of the patent (see Figure 4 above), and that the alleged elimination or substantial reduction of absorption peaks in the patent is thus misleading. I disagree. The evidence shows that the primary absorption peaks for polymers are at the two wavelength ranges of 3.3-3.6 μm and 6.6-6.7 μm , as discussed more fully below, and that this would form part of the common general knowledge of a POSITA at the relevant time.

(c) *The Person Skilled in the Art (POSITA)*

[43] The parties' experts generally agreed on who the POSITA would be as addressee of the '376 Patent. In terms of education, the POSITA would require a university bachelor's degree or a technical school diploma. In terms of work experience, the POSITA would have industrial experience in polymer processing and/or pipe manufacture.

[44] However, the experts disagreed on the extent of knowledge the POSITA would have relating to IR radiation and details of IR lamp construction. While the Plaintiff's experts agreed that the POSITA would know fundamentals of IR radiation, Dr. Boreman on behalf of the Defendants stated that the POSITA requires a higher level of IR science and optics to be able to practice the invention upon reading the '376 specification.

[45] I find that the POSITA, in order to understand and be able to follow the specification and claims of the '376 Patent and thereby be enabled to practice the '376 invention, would:

- a) have a university bachelor's degree or technical degree or diploma in industrial chemistry, polymer chemistry or polymer science;
- b) have knowledge of polymer processing and extrusion of polymer products;
- c) know how to use IR radiation in processing polymers with 3 to 5 years industrial experience, to the extent there is a basic understanding of IR apparatus used for crosslinking polymers; and
- d) know how to calculate a polymer's IR absorption profiles at different wavelengths, through personal knowledge or by accessing relevant reference materials available at the publication date.

(d) *Common General Knowledge*

[46] Common general knowledge is the knowledge generally known by the POSITA at the relevant time. It includes what the POSITA may reasonably be expected to know and be able to find out. One must assess what knowledge the POSITA would have obtained through a reasonably diligent search conducted using the means available at the relevant time.

[47] A POSITA's common general knowledge cannot be assumed but must be proven with fact evidence on a balance of probabilities.

[48] In *Eli Lilly & Co v Apotex Inc*, 2009 FC 991 at para 97, Justice Gauthier adopted with approval the comprehensive description of common general knowledge from *General Tire & Rubber Co v Firestone Tyre & Rubber Co*, [1972] RPC 457 (UKHL) at 482-483:

- a) The common general knowledge imputed to such an addressee must, of course, be carefully distinguished from what in patent law is regarded as public knowledge;
- b) Common general knowledge is a different concept derived from a common sense approach to the practical question of what would in fact be known to an appropriately skilled addressee - the sort of man, good at his job, that could be found in real life;
- c) Individual patent specifications and their contents do not normally form part of the relevant common general knowledge, though there may be exceptions.
- d) Regarding scientific papers generally:
 - i. It is not sufficient to prove common general knowledge that a particular disclosure is made in an article, or series of articles, or in a scientific journal, no matter how wide the circulation of that journal may be, in the absence of any evidence that the disclosure is accepted generally by those who are engaged in the art to which the disclosure relates;
 - ii. A piece of particular knowledge as disclosed in a scientific paper does not become common general knowledge merely because it is widely read, and still less because it is widely circulated;
 - iii. Such a piece of knowledge only becomes general knowledge when it is generally known and accepted without question by the bulk of those who are engaged in the particular art; in other words, when it becomes part of their common stock of knowledge relating to the art;
 - iv. It is difficult to appreciate how the use of something which has in fact never been used in a particular art can ever be held to be common general knowledge in the art.

[49] I agree. In this case, based on the evidence before the Court, a POSITA would have understood the following as the common general knowledge at the relevant dates for claim construction and for consideration of validity:

- a) the features of polymers at a molecular level, including knowing which polymer formulations are suitable for particular purposes (such as using HDPE for pipe manufacture) and what happens upon crosslinking of polymers;
- b) the various methods used to manufacture extruded polymer products generally (not solely in relation to the pipe industry);
- c) that IR radiation can be used in manufacturing of polymers;
- d) that sources of IR radiation emit a distribution of wavelengths which peak in intensity in a given area depending on the temperature of the IR source, and that the peak intensity shifts towards shorter IR wavelengths as temperatures rise;

- e) the characteristic distribution curve of IR radiation, which illustrates that there is less transmittance of wavelengths further from the peak of the curve;
- f) that each polymer, depending on its molecular structure, will absorb certain IR wavelengths, known as the polymer's characteristic absorption profile;
- g) how to determine the characteristic absorption profile for any specific polymer;
- h) that IR absorbed at the surface of a polymer would lead to localized and non-uniform heating of the polymer; and
- i) to use IR radiation that would not be absorbed only at the surface, but which rather penetrates the polymer to achieve uniform heating.

III. Preliminary Issues

A. *Relevant Dates for Anticipation, Obviousness: claim date (priority documents)*

[50] The Claim Date for each claim in the PCT application which was granted as the '376 Patent is the relevant date for prior art references for consideration of anticipation and obviousness.

[51] The '376 Patent was issued in Canada following national entry of PCT Application SE 1996/001169, which was filed on September 20, 1996, in Sweden. This PCT application claimed priority from three earlier Uponor patent applications filed on the following dates:

- a) 9503272-8 (Sweden), filed September 20, 1985;
- b) 9600091-4 (Sweden), filed January 11, 1996;
- c) PCT/EP96/02801 (PCT), filed June 26, 1996.

[52] The legal test governing priority claims to earlier filed applications is set out in section 28.1 of the *Patent Act*. This section states that the date of a claim in an application [the Claim Date] is the filing date of the application (defined in section 28), unless a proper request for priority to one or more earlier patent applications has been made. To qualify, the request for priority must have (i) been made within 12 months of the earlier application, and (ii) the subject

matter defined by the claim in the application at the time of the national entry in Canada must have been disclosed in the earlier filed application(s).

[53] I have reviewed the subject matter of the priority applications relied upon by the Plaintiff and find that the claim for priority in respect of the claims in issue, as asserted by the Plaintiff, claims 1 to 4, 7 to 9, 11, 12, 14 to 17, 19, 22 to 27, 29, 30 and 32 to 38, is not justified. There is no disclosure of the irradiation of polymer material with IR radiation wherein the wavelengths corresponding to the absorption peaks for the polymer material have been eliminated, essential elements of independent claims 1 and 19 and all dependent claims thereon. The relevant claim date for obviousness and anticipation is therefore September 20, 1996.

[54] However, I agree with the Plaintiff that the application of a claim date of September 20, 1995, or September 20, 1996, is of no consequence, as no prior art relied upon by the Defendants fall within that window.

B. *Inventors' Liability under Section 53 of the Patent Act*

[55] The Defendants, Pexcor and Heatlink, have alleged that the '376 Patent is void, as the request for national phase entry date of March 18, 1998, contains untrue material allegations wilfully made for the purpose of misleading. In particular, that the inventors (Sjöberg, Rydberg, and Järvenkylä), the applicant (Uponor B.V.), and all other entities claiming an ownership interest in the '376 Patent prior to its date of issuance, knew or were reckless in not knowing that the priority applications did not disclose the subject matter defined by any of the claims of the '376 Patent, as issued or as pending at any time.

[56] For a patent to be void under subsection 53(1) of the *Patent Act*, the Court must find that there is an untrue allegation made in the petition, that it is material, and that was willfully made for the purpose of misleading:

53 (1) A patent is void if any material allegation in the petition of the applicant in respect of the patent is untrue, or if the specification and drawings contain more or less than is necessary for obtaining the end for which they purport to be made, and the omission or addition is willfully made for the purpose of misleading.

[57] I agree with the Plaintiff that the *Patent Act* explicitly contemplates that the allegation must be made by the application. The inventors of the '376 Patent, Sjöberg, Rydberg, and Järvenkylä, were never “applicants” and as such, no duty is imposed against them (*Ratiopharm Inc v Pfizer Ltd*, 2009 FC 711 at para 115).

[58] In any event, the inventors were not involved in patent drafting. The evidence shows that:

- a) Sjöberg testified he had no role in selecting the priority applications;
- b) the Defendants dropped this allegation against Rydberg prior to his testimony; and
- c) Järvenkylä may have had some input at the time, but would not have had the authority to make the final decision.

[59] For an allegation to be material it must somehow affect how the public makes use of the invention taught by the '376 Patent. The only effect of an improper priority claim in this case would be that the applicant would not be entitled to the benefit of the earlier claim date of September 20, 1995, and instead the claim date would be September 20, 1996. This would not and does not impact how the public would make use of the invention.

[60] As was held by Justice Thurlow in *Canadian Marconi Co v Vera Prinzen Enterprises Ltd* (1964), 46 CPR 97 at 141 (Ex Ct), an improper claim to convention priority based on a U.S. application was not a material allegation in the petition which renders the patent void.

[61] As well, there is no evidence before the Court to suggest that the priority dates claimed were made with any intent or purpose to mislead the Canadian public.

[62] Moreover, the Defendants should have known that the inventors were not responsible for the claims to priority in the '376 Patent application.

[63] This is not a case where the inventors are the applicants and responsible for preparing and filing the application for the '376 Patent, which might in some cases lead to potential liability for an individual inventor under section 53.

[64] To the contrary, the applicant is a sophisticated company who in the normal course employs qualified patent agents or counsel to prepare such an application. To impute liability on the inventors in this case defies logic or reasonableness. Consequences must flow in terms of costs against the Defendants on this front.

IV. Fact Witness Evidence

A. *Bill Gray*

[65] Bill Gray has been the President of Uponor North America since February 2012. In this role, he oversees sales marketing and overall performance of all North American operations. Mr.

Gray is also a member of the Executive Committee of Uponor Corporation, where he makes decisions relating to the brand, technology and people strategy. Mr. Gray testified that the North American Uponor plants use the Engel method or a modification thereof for manufacturing PEX pipe. The '376 Patent technology is only used by the Uponor plants in Sweden and Poland. Mr. Gray also testified that Uponor AB holds the '376 Patent rights.

B. *David Harget*

[66] Dr. David Harget is the VP of Standardization for the Uponor Group. He has a Bachelor's degree in chemistry, a Master's of Polymer Science, a PhD in Polymer Chemistry and 40 years of industry experience. In or around 2006, Mr. Harget was the VP of Technology for Uponor Group and was indirectly involved in the commercialization of the invention taught in the '376 Patent. He testified he reviewed disclosures of possible patentable inventions to decide whether to proceed with patents, but the ultimate patent decisions were made at an executive level. Mr. Harget wrote an article in 1992 regarding the performance characteristics of PEX pipe, which would have been read by people in the field. The article states that a major area of application of PEX is in the power cable industry, which Mr. Harget stated he learned from a review of the literature for the use of PEX at that time.

C. *Jan Rydberg*

[67] Jan Rydberg, a named co-inventor of the '376 Patent, has an engineering degree and a Master's of Science in material technology. He began working for Wirsbo in 1995 as a Development Engineer, where he reported to Michael Sjöberg as member of the High Speed PEX Project development team that developed the '376 Patent. His job on the team was to find

equipment for trial runs that were carried out in Finland and which measured speed, efficiency and crosslinking achieved. He testified that the vertical orientation of the IR lamps was Mr. Sjöberg's idea. Mr. Rydberg did not know the whereabouts of notes and trial reports relating to the development of the '376 invention. In fact, there is no evidence at all with respect to what happened to lab books, trial reports, or any other documents relating to the invention's development.

D. *Michael Sjöberg*

[68] Michael Sjöberg is a named co-inventor of the '376 Patent. He has a Master's of Science in polymer processing and an MBA. He began working for Wirsbo as a Development Engineer in 1990, and his initial work involved developing new methods for making PEX pipes. Mr. Sjöberg was the project leader on the High Speed PEX Project that led to the '376 invention. He testified that during development of the '376 technology, he, and a team of five or six others working on trials kept daily notes and made quarterly and monthly reports, comprising approximately a meter high of lab notebooks. They were not produced in evidence and he has no idea what happened to them. He was not involved in the patent drafting and had no role in selecting the priority applications; Mr. Järvenkylä was responsible for the patent activities involving the '376 invention. Mr. Sjöberg left Uponor in 2001.

E. *Jan Robertson*

[69] Jan Robertson was the sole fact witness called by the Defendants. He has held various roles at Infrarodteknik AB [IRT], a specialized short-wave IR supplier, between 1979 and 2001. IRT purchased their IR lamps from Philips, which are referenced in the IR Handbook – a

document he and others at IRT referred to often in the course of their work. He testified that IRT provided monocassettes and technical support to Aarne Heino (Crosslink). He does not know what information Mr. Heino then conveyed to Pexcor in Canada.

V. Expert Witness Evidence on Claim Construction and Validity

[70] All of the expert witnesses were provided with the relevant tests for claim construction for Canadian patents based on the Supreme Court of Canada decisions in *Free World Trust*, above, and *Whirlpool*, above, as instructed by counsel. They were also instructed on patent infringement and validity based on relevant patent law in Canada.

[71] The expert evidence regarding validity centered on issues of utility, breadth of claims, sufficient disclosure and anticipation and obviousness. In addressing both anticipation and obviousness the Defendants relied on the following four references:

- a) United States Patent No. 4,234,624 (1980) [the '624 Patent];
- b) The IR Handbook published by Philips (1974) [the IR Handbook];
- c) Electric Infra-Red Heating for Industrial Purposes, O'Connell JR et al (1989) [Electric IR Heating];
- d) Polymer Processing: Principles and Design Baird Chapter 15 – Plastic Extrusion Technology (1995) [Polymer Processing].

A. *Plaintiff's Expert Witnesses*

- (1) Dr. Gene Palermo

[72] Dr. Palermo is a polymer chemist who has worked in the plastic pipe industry for over 40 years. He obtained a BSc in Chemistry in 1969, and a PhD of Analytical Chemistry from Michigan State in 1973. His industry experience encompasses manufacturing, formulation, testing, standards, technical and regulatory approvals and marketing new plastic piping materials.

He was also Technical Director of the Plastic Pipes Institute (PPI) and is currently an independent consultant in the plastics pipe industry.

[73] Dr. Palermo has been qualified as an expert in plastic pipes, including material used to make pipes, technical characteristics and standards for pipe, pipe manufacturing and IR spectroscopy for polymer pipes.

[74] In Dr. Palermo's opinion, the invention of the '376 Patent relates to a process and apparatus for a "fast, contactless, and uniform heating" of a polymer or polymer mix using IR radiation with wavelengths which differ from the wavelengths that are absorbed by the polymer. The patent describes that the IR radiation zones are oriented vertically to reduce deformation due to gravitational forces.

[75] Dr. Palermo interprets the term "elimination" of wavelengths (in claims 1 and 19) corresponding to the absorption peaks as not requiring complete absence of those wavelengths, but rather a substantial reduction. He testified that the skilled person would know the wavelengths have been "eliminated" in accordance with the '376 Patent if the IR radiation intensity were reduced by 50%.

[76] He interprets that "filtered out" in the '376 Patent indicates using filters between the IR source and the object being irradiated to help eliminate wavelengths of the material's absorption peaks. Dr. Palermo testified that the filters "augment" or "assist" the reduction of absorption peaks, and the examples provided in the '376 Patent – silica glass, Pyrex or Crown glass – would

all have this effect. During cross-examination it was pointed out to Dr. Palermo that the '376 Patent indicates that an *alternative* to filters is to use IR lamps having wavelengths of about 1.2 μm ('376 Patent, p 9, lines 37-38). The plain reading of the '376 Patent specification does not support Dr. Palermo's opinion that "the two kind of work together".

[77] Dr. Palermo also testified on cross-examination that an additive, such as peroxide, is required to crosslink polyethylene: it cannot be done by heat alone. The validity analysis of claim 7, which stipulates crosslinking may be achieved with *or without* crosslinking additives, addresses this issue below.

[78] On cross-examination, Dr. Palermo also testified that a POSITA in 1995, as characterized by him, would have been aware of power cables with polyethylene coatings, but would not have been familiar with their processing. He admitted the skilled person could have known about use of PEX insulation in the cable industry, and could have referenced this information prior to its use in the pipe industry. He also testified that a cable with polyethylene coating heated by IR, as taught in the prior art (the '624 Patent), would be considered "contactless" heating with respect to the outer surface of the coating.

[79] Dr. Palermo further testified that high, medium and low-density polyethylene (HDPE, MDPE and LDPE) would all have similar absorption peaks. Thus using a theoretical representation of polyethylene's absorption spectrum that does not disclose the type of polyethylene measured is not misleading or problematic.

[80] As well, he testified it is insignificant that Figure 4 of the '376 Patent does not depict wavelengths shorter than 2.5 μm (4000cm^{-1}), as polyethylene has characteristic absorption peaks in the mid-IR range (between 500 and 4000cm^{-1}), and typically no absorption peaks below 2.5 μm . He admits that the equipment used to generate IR spectrum in the short-IR range, not depicted in Figure 4, was available in 1995.

[81] Dr. Palermo agreed that although the vertical arrangement of the IR ovens is an option in the '376 Patent that does not appear until the final two process claims 16 and 17, the benefit of the invention would be lost if one were to use a horizontal, rather than vertical orientation. Dr. Palermo also stated that the arrangement of lamps, depicted in Figures 2A and 2B of the '376 Patent, as well as the vertical orientation of IR zones, are "logical" arrangements for use by a POSITA prior to 1995 in processing polymer material.

(2) Dr. Robert Kimmel

[82] Dr. Kimmel has close to 60 years' experience working with polymers and polymer products. He holds four degrees from M.I.T., including a PhD in Materials Engineering, and has worked in the industry for over 30 years at Hoechst North America, a diversified polymer products company.

[83] He is currently Associate Professor of Packaging Science at Clemson University, South Carolina, where he has worked on many products involving extruded components and has developed and taught courses involving principles and applications of IR heating of plastics.

[84] Dr. Kimmel was qualified at trial as an expert in polymer science, manufacturing with polymers and extruded polymer products, in particular with respect to polymer films.

[85] Although Dr. Kimmel agreed with Dr. Palermo that “eliminated” in the context of the ‘376 Patent signifies substantially reduced, rather than 100% removed, he did not and could not quantify what reduction percentage constitutes “substantial reduction”.

[86] With respect to “filtering” described in claim 2, Dr. Kimmel testified that quartz glass (containing SiO₂) used in Pexcor’s process filters the 6.6-6.8 μm peak and partially filters the 3.3-3.6 μm peak – polyethylene’s primary absorption peaks. During cross-examination it was pointed out that quartz glass only reduces wavelength emission by 10% or 12% in the 3.2-3.6 μm ranges, which is not “substantial reduction”. Dr. Kimmel attempted to explain it is important to also know the IR source, as its combination with the filter affects the result, (i.e. claim 2 depends on claim 1). In his view, it is necessary to examine the end product to determine if the ‘376 process was properly executed, and similarly whether there was infringement.

[87] Dr. Kimmel testified that filters are unnecessary if one uses an IR lamp with 1.2 μm intensity. However, he stated filters could be used to enhance reduction of wavelengths corresponding to polyethylene’s absorption peaks. He qualified that the wording “suitable filters” in the ‘376 Patent does not necessarily mean only silica glass, Pyrex or Crown glass – these are examples. In his view, discerning which filters to use to obtain the desired result would either fall within the common general knowledge of a POSITA, or they would find out from a specialist.

[88] Dr. Kimmel's report describes that tungsten filament lamps had been used to heat polymers prior to 1995. He opined that the skilled person in 1995 would either know, or be able to obtain from an IR equipment manufacturer, the peak IR wavelengths emitted by tungsten filament lamps. Thus, as he stated on cross-examination, to determine what IR radiation to use for achieving the claimed elimination, and thus to follow the teaching of the '376 Patent and make and use its claimed invention in 1995, a skilled person would go to others skilled in IR heating.

[89] Dr. Kimmel testified that the most important absorption peaks for polyethylene are at 3.2-3.6 μm , which corresponds to the carbon-hydrogen bonds, and 6.7-6.9 μm , relating to the carbon-carbon bonds. The '376 Patent teaches reduction at those peaks, particularly at 3.2-3.6 μm , where the majority of the absorption takes place in polyethylene and in any polymer. He testified that using a lamp with a wavelength of 1.2 μm results in substantial reduction of absorption peaks in polyethylene.

[90] In assessing validity, Dr. Kimmel's report reviews each claim in light of the four references relied upon for anticipation: the IR Handbook, Electric IR Heating, the '624 Patent and Polymer Processing. He finds that to anticipate claim 1 and the dependent claims, it would be necessary for the reference to disclose a particular polymer, direct the POSITA to consider its absorption profile, and direct the use of IR radiation that avoids that polymer's absorption peaks – which is not disclosed in any of the prior art.

[91] I disagree with this characterization. The prior art's disclosure does not have to be an "exact description" of the claimed invention, and the disclosure when carried out may be done without a person necessarily recognizing what is present or what is happening. Anticipation is found where performance of the prior art necessarily infringes the patent under review (*Abbott Laboratories v Canada (Minister of Health)*, 2008 FC 1359 at para 75 [*Abbott Laboratories*], aff'd 2009 FCA 94; *Sanofi-Synthelabo Canada Inc v Apotex Inc*, 2008 SCC 61 at para 25 [*Sanofi*] citing *Synthon BV v Smithkline Beecham plc*, [2005] UKHL 59 (UK HL) at para 23). Thus, to anticipate claims 1 and 19 of the '376 Patent, the prior art need not specifically direct the POSITA to remove wavelengths corresponding to the absorption peaks of a particular polymer, so long as that would be an inevitable consequence of the prior art's teachings and understood by the POSITA as necessary to achieve the desired result in polymer processing as taught by the '376 Patent.

[92] Dr. Kimmel found that the main process and apparatus claims 1 and 19, and the remaining dependent claims, were not anticipated in the literature pre-1995. In fact, Dr. Kimmel described that the concept taught in the '376 Patent is counterintuitive to what was known in 1997, when IR radiation was used to match the absorption peaks for the material being irradiated so as to heat it quickly and minimize power consumption in a process called thermoforming.

[93] Neither the IR Handbook nor Electric IR Heating disclose any particular polymer: these are general references explaining the use of IR for various purposes. The POSITA would not understand the statements in these references to indicate that the absorption peaks are being eliminated.

[94] Polymer Processing also does not disclose the invention: it discusses the areas of transmission of polyethylene terephthalate, but does not direct the POSITA to use any particular wavelengths of IR radiation to irradiate that polymer. However, Dr. Kimmel did agree with the statement in Polymer Processing that the advantages to having the polymer partially transparent to the incident radiation are internal absorption in the polymer sample, which results in more uniform heating of the material, and agreed the same information is given in the '376 Patent.

[95] Dr. Kimmel's report also finds that the '624 Patent does not disclose elimination of the polymer's absorption peaks. In the '624 process described, the polymer layer is coated on top of the cable core, which contains a metal wire and a carbon black layer. Dr. Kimmel explains that the carbon black layer re-radiates IR at the frequencies it most absorbs, resulting in the polymer being irradiated with multiple sources of IR radiation, and no elimination of the wavelengths corresponding to its absorption peaks.

[96] Dr. Kimmel's above analysis applies as well to claims 2 to 6. Claims 7 to 18 are only analyzed with respect to the '624 Patent. Claims 16 and 17, pertaining to the vertical orientation of the IR zones, are also not anticipated by the '624 Patent, as it does not disclose extruded tubes or vertical feeding through IR zones.

[97] In Dr. Kimmel's opinion, apparatus claims 19 through 38 are also not anticipated for the reasons set out above regarding the process claims.

[98] On cross-examination, Defence counsel referred Dr. Kimmel to portions of the '376 Patent specification relating to claims 20 and 21 ('376 Patent, p 12, lines 35-38), which convey that the extrusion forming tool may be made using material that is both transparent and which filters IR radiation. Dr. Kimmel had trouble explaining what he understood to have been intended by the inventors and could not explain how the same glass can be transparent and also a filter for the same wavelengths.

[99] Dr. Kimmel's attention was also drawn on cross-examination to an extract from "Plastics Extrusion Technology" (1988) (Seydel Report, Exhibit G), which states that use of PEX in the cable industry was the real impetus behind the development of various crosslinking processes (p. 490). Dr. Kimmel has no experience in the cable industry and could not confirm the understanding taught in that reference.

[100] In assessing the '624 Patent as prior art, Dr. Kimmel opined that a POSITA would be confused and could not follow what is written or reproduce what was done in the '624 Patent. I find this position difficult to reconcile with the fact he apparently has no trouble understanding the '376 Patent, which discloses significantly less information about how to make or use the invention in the specification than does the '624 Patent specification.

[101] The '624 Patent teaches use of an inner conductor that reflects IR radiation. Although Dr. Kimmel maintained this is a point of distinction between the '376 and '624 Patents which renders this prior art not anticipatory or obvious, he later agreed on cross-examination that it would have the same scientific effect on the radiation as the aluminium reflective layer described

in the '376 Patent, and that the reflection principles of IR radiation are similar between the '624 and '376 Patents.

[102] The '624 Patent states that short-wave IR radiation passes through the polyethylene, resulting in rapid through heating of the cable conductor/inner conducting layer and rapid crosslinking of the polymer. Dr. Kimmel did not agree that uniform crosslinking will necessarily result from the '624 Patent, as additional components not present in the '376 process may have an unknown effect. Dr. Kimmel explained the comparison between the '624 and '376 processes is not apt because in the '624 Patent the inner tube is not hollow, which results in a complex heat transfer situation. On this point, Defence counsel pointed out that the aluminum interior in both patents reflects the IR radiation. Dr. Kimmel testified he did not know the effect of the aluminum layer on crosslinking, yet, he agreed that the inventors of the '376 Patent claim it causes uniform crosslinking.

[103] The '624 Patent describes heating a polymer material, LDPE, using IR radiation emitting wavelengths at 1.2 μm to instigate crosslinking. Dr. Kimmel agreed that this process involves heating a polymer material, polyethylene, for the purpose of crosslinking by way of IR radiation at a peak intensity of 1.2 μm . He initially did not agree that if a person follows the '624 process they would be eliminating wavelengths corresponding to the absorption peaks for polyethylene, but upon further questioning agreed that elimination was taking place in the '624 Patent. His uncertain and equivocal testimony raises doubt about the weight to be given this evidence.

[104] Dr. Kimmel also conceded that the peroxide mentioned in the '624 Patent is an organic peroxide, and that the wavelengths of the IR used fall outside the 3.2-3.6 μm and 6.7-6.9 μm ranges, as well as the 2-10 μm range, as required by the '376 Patent. As well, he admitted that the skilled person carrying out the '624 process would use IR radiation having a wavelength substantially located around 1.2 μm . The '624 process also requires the use of nitrogen to prevent oxidation, and the polymer is extruded continuously.

[105] Dr. Kimmel disagreed that a vertical manufacturing process for a pipe would be obvious in light of the fact it was used for cable prior to 1995. Yet, he acknowledged that the broad application of the '376 invention is not limited to pipes: it describes a process for the manufacture of tubes which could later be heated and expanded as a liner for another tube - such as for cable lining production.

[106] A POSITA, as defined by Dr. Kimmel, would not have a good understanding of how polymers respond to IR radiation, but would at least understand Figure 4 of the '376 Patent. Dr. Kimmel thinks the POSITA would seek assistance from a supplier knowledgeable in IR to learn which lamps to use for irradiating the polymer material. I disagree with this characterization, as the invention centers on selection of IR wavelengths. The specification and claims, along with the POSITA's common general knowledge, must be sufficient to enable the POSITA to carry out the invention as claimed.

B. *Defendants' Expert Witnesses*

(1) Dr. Glenn Boreman

[107] Dr. Boreman is currently Professor and Chair of the Department of Physics and Optical Science at University of North Carolina at Charlotte and is Director of the Center for Optoelectronics and Optical Communications. He was also professor for 27 years at University of Central Florida. He has conducted research on IR technology, has authored numerous texts, chapters and articles, and has been on the editorial board of a number of journals in the field of optics. He obtained his PhD in Optical Sciences from the University of Arizona in 1984, and obtained a Master's in 1981 and BSc in 1978.

[108] Dr. Boreman has been qualified as an expert in the physics of IR radiation and IR technology.

[109] Dr. Boreman admitted he is not an expert in emitter technology for polyethylene pipes and has not worked in manufacturing plants. Thus, his expertise is limited to what a POSITA would need to know about IR radiation to practice the patent, and does not involve heating polymers – the second major aspect of the '376 Patent.

[110] According to Dr. Boreman, the term "elimination" would require the skilled person to first ask what is being eliminated (a qualitative issue), and would require them to determine how much elimination is required (a quantitative issue).

[111] Dr. Boreman agreed with Drs. Palermo and Kimmel that the term “eliminated” does not require 100% elimination. To define “elimination” he stated a skilled person would use the blackbody IR spectrum, which demonstrates theoretical measurements of an idealized substance that absorbs all radiation, to calculate that if the relative intensity of IR radiation at a wavelength around 3.4 μm is 20% or less, “elimination” has occurred.

[112] On cross-examination, Dr. Boreman agreed he took an academic approach to interpreting the ‘376 Patent, as otherwise, he could not interpret the meaning of “elimination”. Although a POSITA would not have had access to all the scientific analytical data Dr. Boreman did, he opined they would have had relevant resource materials to refer to for an understanding of his interpretation of the ‘376 Patent at the relevant date.

[113] Dr. Boreman’s report states that the skilled person would conclude that using any of the suggested examples of glass filter materials in the ‘376 Patent (silica glass, Pyrex or Crown glass) would eliminate both stated absorption peaks from IR radiation. However, this is not the case: due to the large variance in the IR transmission of each filter, a POSITA would be at a loss to determine what is meant by “wavelengths corresponding to the absorption peaks are eliminated” based on the suggestion that these materials act as filters.

[114] Dr. Boreman found Figure 4 of the ‘376 Patent “puzzling”, given the y-axis starts at value of 1.44 rather than 0, and has top value of “T” rather than 100%, and only shows the IR curve from the lowest wavelength value of 4000cm^{-1} (2.5 μm). As well, Figure 4 does not indicate the thickness of polyethylene measured, which he states affects radiation transmission.

[115] Dr. Boreman's report also concludes that the inventive concept of the '376 Patent is a known application of various principles of physics. This concept along with the supposed benefits of the elimination claimed in the '376 Patent were previously described in a number of prior art documents.

[116] In analyzing novelty of the '376 invention, Dr. Boreman's report states that the IR Handbook discloses that short-wave IR having a peak at 1.2 μm can be used to heat a polymer rapidly and uniformly without damaging the surface – exactly what is taught by the '376 Patent. In his opinion, the IR Handbook anticipates claims 1 and 19.

[117] Polymer Processing teaches that radiation absorbed internally provides more uniform heating of the material relative to radiation absorbed at the surface, which Dr. Boreman opines is the key teaching of claims 1 and 19 of the '376 Patent.

[118] The '624 Patent describes a method of applying insulation of crosslinked polymer on a cable conductor. It teaches use of IR radiation for crosslinking the polymer insulation, transmitted into the interior of the polymer, which allows for rapid heating through its cross-section. It lists polyethylene as a suitable polymer and teaches using peroxide as an additive to effect crosslinking. The radiation source may consist of several IR lamps with tungsten filaments operating at 2100°C, thus providing radiation with maximum intensity at a wavelength of 1.2 μm .

[119] Dr. Boreman thus finds that the '624 Patent describes the invention claimed in claims 1 and 19 of the '376 Patent. It involves: (i) use of an IR lamp to crosslink extruded polyethylene; (ii) that the IR radiation should penetrate into the polyethylene material and not be absorbed at the surface; and (iii) irradiation with an IR lamp having a peak wavelength of 1.2 μm , which provides rapid through-heating of the polymer.

[120] However, Dr. Boreman admitted that the '624 Patent's non-optional use of pressure within a vulcanization tube is not "contactless", and thus is not part of the '376 Patent. He agreed that a person reading the '624 Patent would have to selectively identify aspects from that patent in order to use the process described therein to implement the '376 Patent.

[121] The final prior art reference relied on by the Defendants, Electric IR Heating, states that "selection of the appropriate wavelength is particularly important for processing plastics", and short-wave radiation is not absorbed at the surface, but is transmitted into and penetrates the polymer material – in Dr. Boreman's opinion, it describes the same physical phenomena as the '376 Patent.

[122] Dr. Boreman opined that the POSITA at the relevant time would consider the inventive concept of claims 1 and 19 to be the heating of a polymer by IR radiation in which wavelengths corresponding to the absorption peaks have been eliminated, and that the extra details provided by dependent claims do not change this concept in any meaningful way. The '376 Patent states that all parts of the described extrusion line, except the IR zones and vertical orientation, are "quite conventional" ('376 Patent, p. 7, lines 12-14).

[123] His report concludes that this inventive concept was well known prior to 1995. With respect to IR radiation, the common general knowledge of a POSITA as of September 1995 would have included all essential elements, namely that heating a polymer using short-wave IR radiation would allow it to penetrate into the polymer, leading to uniform heating without surface damage.

[124] I note that Dr. Boreman's expertise is limited to the IR radiation aspect of the patent: it does not extend to polymer processing and extrusion of polymer products. Thus, his opinion of the importance of dependent claims, which he did not individually assess, is afforded little weight.

(2) Dr. John Dutcher

[125] Dr. Dutcher is currently Professor in the Department of Physics at the University of Guelph. He has taught several graduate courses and is author of numerous articles on polymer physics. He was appointed as Tier 1 Canada Research Chair in Soft Matter Physics in 2006 and in Soft Matter and Biological Physics in 2013. He obtained his PhD from Simon Fraser in 1989, and has a Master's of Science in Physics (UBC) and a Bachelor's of Science (Dalhousie).

[126] Dr. Dutcher has been qualified as an expert in polymer physics.

[127] Dr. Dutcher's report finds that the entire '376 Patent is based on incorrect data regarding the IR absorption of polyethylene, is based on fundamentally flawed reasoning, and would mislead the skilled person.

[128] In his opinion, the “elimination” of wavelengths corresponding to the polymer’s absorption peaks does not occur in the ‘376 Patent and neither does the claimed elimination occur in the Pexcor process. Furthermore, the supposed inventive concept of the ‘376 Patent was disclosed in a number of prior documents.

[129] Regarding claim 1 of the ‘376 Patent, Dr. Dutcher found it unclear what constitutes “substantial reduction”. He estimated that applying IR radiation at around 1.2 μm , there may be a 66% reduction at 3.3-3.6 μm peak, but he qualified that one would have to experiment to figure out if that level of reduction is sufficient for the purposes of the ‘376 Patent.

[130] Dr. Dutcher agreed that a POSITA would understand that “elimination” in the context of the ‘376 Patent does not require complete elimination of the wavelengths corresponding to absorption peaks. The POSITA would determine the amount of “elimination” necessary for the ‘376 claims by referencing the information provided in the patent; by using filters and IR radiation with specified wavelengths. He testified it is important to know all absorption peaks of the polymer, including within the short-wave range, to be able to “eliminate” and avoid overheating the polymer.

[131] Dr. Dutcher’s report states that the wavelengths corresponding to polyethylene’s absorption peaks are not eliminated in the ‘376 Patent. The wide variance in “filtering” obtained by silica, Pyrex or Crown glass would render the POSITA at a loss to understand how to quantify the amount of filtering necessary for “elimination”, and thus whether the elimination required by the claims of the ‘376 Patent is or is not occurring. For instance, silica glass transmits 85% and

60% of the incident radiation at wavelengths corresponding to polyethylene's absorption peaks, and Pyrex transmits 45% and 10% respectively.

[132] Dr. Dutcher also found Figure 4 of the '376 Patent to be misleading because it does not extend to the short-wave IR region. His report produces a "more complete IR spectrum" for 2 mm thick polyethylene, obtained online from an optics company, Tydex Optics [the Tydex Graph]. He claims the Tydex Graph demonstrates polyethylene has a "significant absorption" peak between 1.7 and 1.8 μm , and another at 1.2 μm . This is the only reference to polyethylene's other absorption peaks in Dr. Dutcher's report. He opines the skilled person would be curious as to the lack of information on smaller wavelengths, not depicted in Figure 4.

[133] Given that the relevant date for construction of the '376 Patent was May 27, 1997, and the Tydex Graph is dated 2010, a POSITA would not have had access to it as of 1997 and would not have been confused by the '376 Patent.

[134] While Dr. Dutcher agreed it is important to know the conditions under which spectra are generated, he did not contact Tydex to ask about the conditions under which the Tydex Graph was generated, nor did he know whether a qualified person made such measurements. He relied on the fact the graph was reproduced by a specialty optics company doing what he considers a very standard measurement. Nevertheless, he did not investigate further to ensure it was a standard measure.

[135] In his view, using the lamp described in the '376 Patent does not "eliminate" or even "substantially reduce" the 1.2 or 1.7 μm absorption peak for polyethylene. Dr. Dutcher opines that the entirety of the '376 Patent is based on an incorrect understanding of the actual physical phenomena occurring and the language of the claims would mislead the skilled person.

[136] With regards to anticipation and obviousness, Dr. Dutcher's report claims that the '376 inventive concept was disclosed in the prior art and he provides a similar analysis to Dr.

Boreman, finding that:

- a) The IR Handbook essentially paraphrases the content of the '376 Patent, and the skilled person would have no difficulty understanding that it anticipates claims 1 and 19.
- b) The '624 Patent's reference to the polymer having "good perviousness" for the radiation for crosslinking would convey to the POSITA that the radiation would be transmitted through the polymer. The '624 Patent also refers to using an IR source with the same peak wavelength as in the '376 Patent – 1.2 μm .
- c) Polymer Processing states the advantages to having the polymer partially transparent to the incident radiation are internal absorption, which provides more uniform heating of the material – the same mechanism of heating described in the '376 Patent.
- d) Electric IR Heating is similar to the IR Handbook, and conveys that short-wave radiation, which generally has a peak wavelength of 1.2 μm , will be primarily transmitted by polymer sheets, which reduces the possibility of scorching the surface – which in Dr. Dutcher's opinion, discloses what is said to be the invention of the '376 Patent.

(3) Franz Seydel

[137] Mr. Seydel studied plastics engineering in Darmstadt, West Germany and has worked in plastic pipe manufacturing and the plastic pipe systems business for over 40 years in a variety of roles, including quality assurance, testing, product and process development, marketing, design, and logistics. He has been a member of international technical committees that developed standards for PEX pipe. Since 2008, Mr. Seydel has been a consultant relating to plastic pipe and plastic pipe systems.

[138] At trial the Plaintiff objected to Mr. Seydel's qualification as expert, citing *R v Mohan*, [1994] 2 SCR 9, and claiming that his testimony was not necessary. I find that Mr. Seydel has specialized knowledge beyond that of the ordinary person and that his opinion related to material issues that are technical in nature and beyond the experience and knowledge the Court is expected to have.

[139] It was on this basis, and a consideration of the other *Mohan* factors (as modified in *R v Abbey*, 2009 ONCA 624, leave to appeal refused, [2010] 2 SCR v (note), and confirmed in *White Burgess Langille Inman v Abbott and Haliburton Co*, 2015 SCC 23 [*White Burgess*]) that I admitted Mr. Seydel's expert evidence. However, ultimately, I afford it little if any weight.

[140] Justice Phelan has recently laid out a comprehensive review of the current law on the role of expert witnesses in *Allard et al v Canada*, 2016 FC 236 at paras 103-108 [*Allard*], which I find appropriate to reiterate. At paragraph 106 of that decision he quotes the Supreme Court's most recent commentary on expert opinion evidence in *White Burgess*, above, stating:

[106] The Court went on to discuss the nature of an expert's duty to the court and where it fits into the [*Abbey*] framework:

27 One influential statement of the elements of this duty are found in the English case *National Justice Compania Naviera SA v. Prudential Assurance Co.*, [1993] 2 Lloyd's Rep. 68 (Eng. Comm. Ct.). Following an 87-day trial, Cresswell J. believed that a misunderstanding of the duties and responsibilities of expert witnesses contributed to the length of the trial. He listed in *obiter dictum* duties and responsibilities of experts, the first two of which have particularly influenced the development of Canadian law:

1. Expert evidence presented to the Court should be, and should be seen to be, the

independent product of the expert uninfluenced as to form or content by the exigencies of litigation...

2. An expert witness should provide independent assistance to the Court by way of objective unbiased opinion in relation to matters within his [or her] expertise.... An expert witness in the High Court should never assume the role of an advocate.
[Emphasis added; citation omitted; p. 81.]

(These duties were endorsed on appeal: [*"Ikarian Reefer" (The), Re*] [1995] 1 Lloyd's Rep. 455 (Eng. C.A.), at p. 496.)

As to admissibility or weight, the following comments were provided:

45 Following what I take to be the dominant view in the Canadian cases, I would hold that an expert's lack of independence and impartiality goes to the admissibility of the evidence in addition to being considered in relation to the weight to be given to the evidence if admitted. That approach seems to me to be more in line with the basic structure of our law relating to expert evidence and with the importance our jurisprudence has attached to the gatekeeping role of trial judges. Binnie J. summed up the Canadian approach well in *J. (J.-L.)*: "The admissibility of the expert evidence should be scrutinized at the time it is proffered, and not allowed too easy an entry on the basis that all of the frailties could go at the end of the day to weight rather than admissibility" (para. 28).

...

54 Finding that expert evidence meets the basic threshold does not end the inquiry. Consistent with the structure of the analysis developed following *Mohan* which I have discussed earlier, the judge must still take concerns about the expert's independence and impartiality into account in weighing the evidence at the gatekeeping stage. At this point, relevance, necessity, reliability and absence of bias can helpfully be seen as part of a

sliding scale where a basic level must first be achieved in order to meet the admissibility threshold and thereafter continue to play a role in weighing the overall competing considerations in admitting the evidence. At the end of the day, the judge must be satisfied that the potential helpfulness of the evidence is not outweighed by the risk of the dangers materializing that are associated with expert evidence.

[Emphasis in original].

[141] The role of an expert is to provide independent assistance by objective, unbiased opinion. Mr. Seydel's evidence was not only "shredded on cross-examination" (*Allard*, above, at para 108), but his opinion strayed into assuming the role of advocate, and was neither independent nor unbiased.

C. *Plaintiff's Responding Reports on Validity*

(1) Dr. Robert Kimmel

[142] Dr. Kimmel's responding report largely responded to and refuted assertions made in Mr. Seydel's report on issues of whether crosslinking agents specified in the '376 Patent actually work and on Mr. Seydel's analysis of the speeds of different extrusion processes. Given my above finding, it is not necessary to describe this evidence.

[143] In response to the other Defence experts, Dr. Kimmel opined that Figure 4 of the '376 Patent is not misleading: the spectrum is simply used to explain the location of polyethylene's absorption peaks.

(2) Dr. Mohamad Al-Sheikhly

[144] Dr. Al-Sheikhly is currently a Professor at the University of Maryland in the Department of Materials Science and Engineering and the Chemical Physics program. He is Director of Radiation and Polymer Science.

[145] Dr. Al-Sheikhly received his PhD in 1981 from the University of Newcastle Upon Tyne (UK). He has held positions at the Max-Planck Institute in Germany and at the National Institute of Standards and Technology in Maryland and has industry experience consulting in respect of manufacturing processes involving polymers and radiation.

[146] Dr. Al-Sheikhly has been qualified as an expert on IR radiation, its applications in manufacturing, and its effect on polymers.

[147] Dr. Al-Sheikhly clarifies in his report that standard IR spectroscopy equipment cannot measure IR absorption along the entire spectrum: different machines measure short-wave IR as compared to mid-wave IR. It is well known that polymers primarily absorb in the mid-IR region; therefore polymer chemists focus on that region when considering IR absorption for a given polymer. Short-wave IR spectra are used for very narrow purposes and are not widely consulted.

[148] Dr. Al-Sheikhly included a graph in his report from the *Journal of Polymer Science* illustrating that Dr. Dutcher's "significant" absorption peak near 1.7 μm is not significant at all. Thus, Figure 4 of the '376 Patent is not misleading for its failure to include the short-wave IR absorption profile. On cross-examination, Dr. Al-Sheikhly admitted he does not know the

machine that generated Figure 4, the conditions under which it was generated, the statistical error, or the scale. He stated you cannot have a negative transmittance, contrary to his evidence in chief.

[149] Dr. Al-Sheikhly stated filters can be made to order. They are widely available today and were available before 1995 in configurations that could be targeted to block virtually any desired wavelengths of IR, including in the mid-IR region. Despite stating that a skilled person would go to a manufacturer to select the appropriate filter for a polymer, on cross-examination Dr. Al-Sheikhly did not agree that the skilled person needs something more than what is written in the patent to understand and use it. Upon further questioning, he agreed that the skilled person would not know what filter to use for a particular polymer without going outside the patent.

[150] Although there were various inconsistencies in Dr. Al-Sheikhly's testimony, I give more weight to his evidence over that of Dr. Dutcher's with respect to polyethylene's absorption peaks at the short-wave region (near 1.7 μm), as his graph comes from a reputable and verifiable source and does not pose the timing difficulties of Dr. Dutcher's Tydex Graph, having been published on February 2, 1996.

VI. Validity Analysis

A. *Unpatentable Subject Matter*

[151] The Defendants Pexcor and Heatlink have pleaded that the '376 Patent is invalid as the purported invention is not proper subject matter under section 2 of the *Patent Act*.

[152] The Defendants assert this ground on the basis that independent claims 1 and 19 disclose “mental steps” and not physical steps. I disagree: selection of a source of IR radiation such that the wavelengths corresponding to the absorption peaks for polymer materials have been eliminated can be a patentable process, so long as the other criteria for patentability are met, namely sufficiency of description in the specification, utility, novelty and non-obviousness, which are discussed below. Moreover, the use of known equipment or apparatus in a novel and unobvious application for crosslinking polymer pipe is also capable of being patentable subject matter, subject to the same requirements for patentability as for the process to carry out the invention.

B. *Utility*

[153] Section 2 of the *Patent Act* requires that the subject matter of a patent be both new and useful. To establish inutility, one must show that the invention will not work, either not at all, or for the purpose(s) promised in the specification. Utility is determined on a claim by claim basis (*Eli Lilly Canada Inc et al v Novopharm Ltd*, 2010 FCA 197 at paras 74-75).

[154] The Defendants allege that the ‘376 Patent lacks utility and is invalid because:

- a) it does not provide “uniform and fast heating of polymers or mixtures of polymer”, as promised;
- b) no heating and crosslinking of polymers will occur if the wavelengths corresponding to all peaks of the polymeric material have been eliminated;
- c) it is not possible to filter an IR lamp to eliminate wavelengths corresponding to the absorption peaks of a polymer using any of the filters disclosed or claimed; and
- d) a polymer material cannot be crosslinked without a crosslinking additive.

[155] The evidence before the Court does not establish either (a) or (b) lack utility, given agreement that “elimination” means substantial reduction, and there is no evidence to suggest

that the alleged inventive process does not provide uniform and fast heating. Only issues (c) and (d) are in dispute and were substantively argued by the Defendants at trial.

[156] There was considerable disagreement over what “elimination” or “substantial reduction” of the wavelengths corresponding to the absorption peaks for polymer material means when “filtered out” by the use of filters. The patent provides no useful definition or disclosure of what constitutes a substantial reduction, and the experts’ opinions of what a POSITA might understand that to mean creates a great deal of ambiguity in being able to ascertain what level of reduction constitutes a “substantial reduction”, further discussed below in assessing sufficiency of disclosure.

[157] The ‘376 Patent states that the absorption peaks for polyethylene (3.2-3.6 μm and 6.7-6.9 μm) can be “eliminated” using filters:

The elimination of these absorption peaks may for instance be achieved by placing a filter filtering off these peaks which is placed between the respective infrared radiator and the tube. A suitable filter material is for instance silica glass, SiO_2 , or the glass types known under the names “Pyrex” or “Crown glass”.

[158] Dr. Palermo and Dr. Kimmel contended that the function of the filters in the ‘376 Patent was to “augment” or “enhance” the elimination achieved by selection of an IR source. The plain wording of the ‘376 Patent states the contrary: “elimination of these absorption peaks may for instance be achieved by placing a filter filtering off these peaks”, and that an “alternative to filters” is the use of a lamp with a peak at 1.2 μm . Thus, the position put forward by Uponor’s experts that the filters “work together” with the IR source to provide “additional reduction” and

achieve elimination is not conveyed by the plain and ordinary meaning of the words as used in the patent and does not have merit.

[159] Second, Uponor's expert Dr. Al-Sheikhly asserted that filters made of the "suitable filter material" could be made to order and that the skilled person would "choose a configuration for a filter that would work to eliminate the desired wavelengths". However, Dr. Al-Sheikhly provided no examples and was unable to identify any such configuration for filtering the 3.2-3.6 μm absorption peak.

[160] Although the specification ends with the statement that "[t]he filters may of course also be of any optional kind" ('376 Patent, p 16), the evidence was that a POSITA would understand that one of the example materials provided in the patent works as a sufficient filter (Dr. Palermo, Cross-examination). If filter materials are detailed within the specification and the claims, a POSITA would consider them to be enabling to carry out the invention.

[161] The evidence of Pexcor and Heatlink's experts, Dr. Boreman and Dr. Dutcher, is that the "suitable filter material" disclosed in the '376 Patent does not work. Specifically, silica glass transmits anywhere from 60% to over 85% of the incident radiation in the 3.2-3.6 μm range. Even based on Dr. Palermo's definition that elimination requires at least 50% reduction in relative intensity, which I do not accept, silica glass does not "eliminate" the IR radiation at this absorption peak.

[162] In addition, the transmission of IR radiation at the 3.2-3.6 μm peak for BK7, a Crown glass described as “one of the most common borosilicate crown glasses used for visible and near infrared optics”, is well over 50%. Crown glass also does not “eliminate” the IR radiation at the 3.2-3.6 μm absorption peak.

[163] I find that the claims providing that the elimination of wavelengths corresponding to the absorption peaks of polymer material by use of the filters disclosed in the ‘376 Patent do not work and are invalid.

[164] As such, claims 2 and 3 and all of claims 4 to 18, as they depend on either claim 2 or 3, are invalid on the basis of inutility. As are apparatus claims relating to filters, 36 and 37, and claim 38, as it depends from claim 36 or 37.

[165] Claim 21 provides that part of a forming tool of the apparatus is made up of a material transparent to IR radiation (as set out in claim 20) which also filters off wavelengths corresponding to the absorption peaks of the polymer material.

[166] A transparent material, on a plain and ordinary reading of the disclosure and given its plain meaning, would not filter IR radiation, and thus again lacks utility. As well, as above stated, the ‘376 Patent provides no useful disclosure of what material filters off wavelengths corresponding to the absorption peaks of a polymer material. The POSITA, although having knowledge of IR and polymer extrusion processes, would not know from the claims or the disclosure in the ‘376 Patent, or according to their common general knowledge, of what the

filters, and thus the forming tool would be made. Claim 21 and each of claims 22 to 38 as they depend from claim 21 are invalid for lack of utility.

[167] Claim 7 of the '376 Patent claims a process "in which a polymer material, which is cross-linkable by means of heat, with or without cross-linking additives, is cross-linked by means of said irradiation with infrared radiation" (emphasis added). The claim therefore includes a process for crosslinking a polymer by heat without the use of a crosslinking additive.

[168] The evidence shows that crosslinking requires additives such as a peroxide or a silane, and cannot be achieved by heat alone. Claim 7 is invalid for lack of utility and is also overbroad. Given that claim 8 wholly depends on claim 7, it is also invalid for lack of utility. Although claims 9 and 10 also depend on claim 8 (and thus claim 7), they qualify the deficiency in claim 7 by requiring a cross-linking additive, and thus are not invalid for inutility.

C. *Insufficiency of the Disclosure*

[169] Subsection 27(3) of the *Patent Act* requires that the specification of a patent correctly and fully describe the invention and the operation or use of the invention as contemplated by the inventor. The steps in a process must be "set out clearly" and the method of manufacture must be described in full, clear and exact terms such that a POSITA could make and use the invention as claimed, without display of inventive ingenuity (*Pfizer Canada Inc v Canada (Minister of Health)*, 2008 FCA 108 at paras 63-64 [*Pfizer*]).

[170] Subsection 27(4) of the *Patent Act* provides that the specification must end with a claim or claims that define the subject matter of the invention in distinct and explicit terms. Sufficient disclosure of the invention is mandatory for the inventor/applicant to be granted a valid patent and the monopoly for an invention (*Teva Canada Limited v Pfizer Canada Inc*, 2012 SCC 60 at para 32 [*Teva*]).

[171] This Court and the Courts of Appeal have repeatedly warned that patentees should take care in not over claiming what is disclosed as the invention and in what they promise as the invention's objects and advantages. Overbreadth of both claims and promises as disclosed may render some or all the claims, and perhaps the patent as a whole, invalid. As well, adequate disclosure of the invention to enable a POSITA to both understand the boundaries of the claimed invention and to make and use the invention once the patent expires is a necessary prerequisite to a valid patent and valid claims in light of the bargain struck between a patentee and the public interest in granting the patent monopoly (*Consolboard*, above, at p 517).

[172] The specification must correctly and fully describe the invention so that the relevant public, the POSITA, from reading the specification, is able to make and use the invention as successfully as the inventor. The questions the Court must address are:

- a) What is the invention?
- b) How does it work?
- c) Having only the specification, can a POSITA successfully produce the invention using only the instructions contained in the disclosure?

Teva, above, at paras 50-51.

[173] The Plaintiff's position is that the concept of the invention is set out at pages 4 to 5 of the '376 Patent. Claims 1 and 19 provide the broadest claims to the invention, with the dependent claims adding elements related to the polymer used, additives, configurations for the path followed by the extruded pipe, and further equipment such as reflectors. The Plaintiff argues that the inventors came up with the idea of using IR radiation where the absorption peaks of the polymer being irradiated are substantially reduced to avoid surface burning, and with the idea of positioning the IR lamps in a vertical orientation to provide sufficient heating and crosslinking.

[174] I find that the key aspects of the '376 Patent invention are (i) elimination (i.e. substantial reduction) of the wavelengths corresponding to absorption peaks of the polymer, and (ii) using the vertical direction in the extrusion and crosslinking process. The evidence at trial demonstrated this second aspect is not simply a preferred embodiment, but is essential to making and using the invention, as the benefit of the invention would be lost by using a horizontal, rather than vertical orientation.

[175] The next matter involves determining how the POSITA is taught by the patent to put this invention into operation. Both independent claims 1 and 19 refer to irradiation of the polymer material with IR radiation, where the wavelengths corresponding to the absorption peaks for the polymer material have been eliminated. This "elimination" of wavelengths – one of the pillars of the invention – is achieved according to the patent specification and claims either through the use of (i) filters, or (ii) an IR lamp emitting radiation at a wavelength which is substantially located around 1.2 μm .

[176] A POSITA would be unable to discern what the inventors intended by the term “elimination” by considering the patent’s filter examples, given the wide range of filtering the materials provide. As well, the above discussion on utility describes why the first mechanism does not work: the skilled reader should not have to undertake a “minor research project” to find a suitable filter material to determine whether the claimed invention of the patent works (*Teva*, above, at para 74).

[177] Thus, the only remaining method of achieving elimination of wavelengths taught in the ‘376 Patent is using an IR lamp emitting radiation at a wavelength substantially around 1.2 μm .

[178] Even with this information, the disclosure fails to identify what quantitatively amounts to elimination of those wavelengths, and to what extent reduction is needed to meet the objective of the alleged invention.

[179] The conflicting expert evidence on what a POSITA would understand at the relevant claim date suggests a POSITA would be unable to read the specification and ascertain to what extent reduction is needed to meet the objective of the alleged invention. Neither expert for the Plaintiff could meaningfully quantify substantial reduction.

[180] In his report on infringement, Dr. Kimmel opined that eliminated meant “substantially reduced”. During his trial testimony however, Dr. Kimmel asserted multiple interpretations of what “eliminated” might mean. On cross-examination, he stated that infringement of the ‘376 Patent can only be determined *after the fact* by conducting an examination of the end-product as

“the only reasonable way to know if we have elimination is to look at the pipe”. He could not otherwise quantify elimination because it “depends too much on the rest of the process”.

[181] By Dr. Kimmel’s reasoning, any successful manufacture of a sufficiently crosslinked polyethylene pipe by IR radiation with good surface finish would infringe the ‘376 Patent, as such an end-product is indicative in Dr. Kimmel’s opinion, that “substantial reduction” of wavelengths has occurred. As Justice Binnie stated (writing for the Court) in *Free World Trust*, above, at para 32:

The claims cannot be stretched to allow the patentee to monopolize anything that achieves the desirable result. It is not legitimate, for example, to obtain a patent for a particular method that grows hair on bald men and thereafter claim that *anything* that grows hair on bald men infringes [Emphasis in original].

[182] I find the same principle applies here, and I give Dr. Kimmel’s evidence on this issue little weight, as it cannot be that the ‘376 Patent affords Uponor a monopoly over any successful manufacture of PEX pipe using IR radiation that produces a good surface finish.

[183] Dr. Palermo testified that as long as the intensity of the radiation at the absorption peaks are more than 50% reduced, the skilled person would know the wavelengths have been “eliminated”, in accordance with the ‘376 Patent.

[184] I also attribute this definition of elimination little weight. There is no basis in the ‘376 Patent for the 50% reduction proposed by Dr. Palermo. I also find the position that “substantial reduction” means anything over 50% reduction is not reasonable. Nor is there any evidence before the Court that a POSITA would consider “elimination” of the absorption wavelengths to

mean that the intensity of IR radiation at the absorption peaks was reduced by only half of the peak intensity.

[185] Dr. Boreman on behalf of the Defendants stated a POSITA would calculate substantial reduction as 20% by referring to a blackbody emission curve. While theoretically, such calculations are possible, Dr. Boreman admitted to have taken a largely academic approach to reading the '376 Patent. Although 20% more reasonably corresponds to the plain meaning of the words "eliminate" or "substantially reduce", there is nothing within the specification or claims leading a POSITA to this percent reduction value over any other. Furthermore, the theoretical and academic manner in which Dr. Boreman interpreted the patent would not have been expected of a POSITA as defined for the '376 invention.

[186] The Court's election of one of these explanations over another seems arbitrary, given that the experts have provided no viable interpretations of "eliminated" which find any principled basis in the claims or specification of the '376 Patent (*Teva*, above) or which were convincing considering the POSITA, as defined.

[187] Despite the absence of information in the specification on what constitutes elimination and the discrepancies in the expert evidence, I am mindful that the Court must endeavour to give a purposive construction to claims, without being overly astute or technical. As well, the Court's interpretation of the required disclosure under subsection 27(3) of the *Patent Act* has been set very low (*Janssen-Ortho Inc v Novopharm Ltd*, 2006 FC 1234 at paras 122-127 [*Janssen-Ortho*], aff'd 2007 FCA 217; *Pfizer*, above, at paras 63-64).

[188] There is some indication by the inventors within the patent specification that illuminate, at least in a qualitative sense, the meaning of the concept of elimination. The specification uses various terms, teaching the skilled person to irradiate with wavelengths which “substantially are not equal” and “mainly differ” from, or “avoid”, the absorption peaks of the polymer (‘376 Abstract; page 4, lines 30-34; page 9, lines 13-16; page 5, lines 23-25; page 9, line 37 - page 10, line 2).

[189] I find that in approaching the patent with a mind willing to understand, the skilled person – knowing the characteristic distribution curve of IR radiation and how to calculate absorption profiles for polymers – could discern that by applying IR radiation with wavelengths substantially located around 1.2 μm , in the short-wave range, that at the peak absorption areas for polyethylene (3.3-3.6 μm and 6.7-6.9 μm) there is substantially reduced intensity of IR radiation being applied to the polymer pipe.

[190] The disclosure in the ‘376 Patent is not so insufficient so as to render it invalid. The expert evidence was that irradiation using 1.2 μm “substantially reduces” wavelengths at polyethylene’s absorption peaks by necessary implication, as the intensity of IR radiation drops significantly from its peak once it reaches 3.3-3.6 μm and 6.7-6.9 μm . However, the invalidity of the filter claims means that the only remaining preferred embodiment is applying IR radiation at 1.2 μm – the wavelength emitted by a common tungsten filament IR lamp. This being the only remaining means to achieve elimination has implications for determining the appropriate breadth of certain claims and for the ‘376 Patent’s validity in terms of anticipation and obviousness, as discussed below.

[191] Although the filter claims have been above invalidated for inutility, I also find that claims 2 and 3 and all of claims 4 to 18, as they depend on either claim 2 or 3, are invalid on the basis of insufficient disclosure, as they do not enable a POSITA at the relevant date to understand what type of filter to use in order to achieve the benefits promised by use of filters.

[192] The suggestion that a POSITA might have been able to go to an outside IR lamp supplier or filter supplier to try to find out what might work does not alleviate the inutility of the filter claims or the insufficiency of the disclosure relating to the use of filters. The POSITA must be able, in light of their common general knowledge, to make the same successful use of the invention as the inventor could at the time of the application, having only the specification (*Teva*, above, at para 50).

[193] In the instant case, the specification and claims refer to filter materials that do not filter IR wavelengths at the desired absorption peaks to carry out the patent's teaching of how to eliminate wavelengths. Nor would a POSITA understand how to do so without difficulty and significant experimentation: none of the expert evidence suggested the POSITA would have knowledge of IR filtering characteristics of various materials; and the POSITA has only a basic understanding of IR apparatus, which may or may not include the presence of filters.

[194] The '376 Patent states the rest of the preferred embodiment of the invention, except the vertical orientation of the IR zones, is "quite conventional" and the other claims were not contentious at trial for insufficient disclosure.

[195] I do however find that claims 1 and 19 are broader than any invention made or disclosed. The claims teach elimination of wavelengths corresponding to absorption peaks of the polymer. However, the only way elimination may be achieved is by applying IR radiation substantially around 1.2 μm , as using filters does not work. The claims omitted mention of this essential requirement for elimination, and were therefore broader than the invention made or described and are invalid.

[196] Furthermore, since the evidence at trial was that the benefits of the invention are lost without the vertical orientation in the extrusion line, and that a crosslinking additive was essential for crosslinking, only the claims that (i) include the vertical orientation of the IR apparatus as an element used to achieve the promised advantage of contactless heating, and (ii) include the use of a crosslinking additive, such as organic peroxide, are valid, and are not broader than the invention made or disclosed in the patent. They are:

- a) process claims 16 (as it depends on 9-15), 17 and 18;
- b) apparatus claims 25 (as it depends on 24, 23, 22, and 19), 26, 27, 28, 29 (as it depends from 25-28), 30, 31, 32, 33 (as it depends from 25-32), 34, 35 (as it depends from 25-34), 38 (as it depends from 25-35).

[197] While the Defendants also seek to impugn the use of Figure 4 of the '376 Patent, given the uncertainty introduced by reference to the number "1.44" at the bottom of the y-axis, I am satisfied on the evidence that a POSITA would understand Figure 4 as demonstrative of where the primary or highest absorption peaks are located for polyethylene. The mid-IR spectrum being shown is appropriate and, despite some discourse between the experts, the evidence conveys the transmission profile is not affected by the thickness of the sample used to generate the profile.

D. *Anticipation*

[198] The relevant date for determining anticipation is September 20, 1996.

[199] As set out by Justice Rothstein of the Supreme Court of Canada in *Sanofi*, above, both disclosure and enablement are required for a prior art reference or prior use to be held to anticipate a claim in a patent. When considering the step of disclosure, the question is whether the invention as claimed, including its special advantages, is disclosed in the prior art (also see *Bell Helicopter-Texton v Eurocopter*, 2013 FCA 219 at para 107 [*Bell Helicopter, FCA*]). Once determined that the subject matter of the invention has been disclosed in the prior art, the question for the purposes of enablement is whether the skilled person would be able to work the invention without undue burden (*Sanofi*, above, at paras 26, 37).

[200] The Plaintiff's position is that as a result of experimentation under a High Speed PEX project, the team of inventors of the '376 Patent developed a contactless process using IR crosslinking ovens to manufacture high quality PEX pipes. That process is allegedly much faster than the previously used Engel method and produced a better quality pipe than the previous PEXEP method. While some argument was made about the admissibility of third party statements in foreign patent file wrappers, I agree with the Plaintiff that such statements are inadmissible as hearsay, as not applying in Canada under the doctrine of file wrapper estoppel, and as not being admissions of the Plaintiff.

[201] As a preliminary comment, the Defendants' experts, Drs. Boreman and Dutcher, both admitted during cross-examination that their opinions and analysis were based solely on

consideration of claims 1 and 19 of the '376 Patent. Their evidence must be viewed with that limitation in mind, and is not afforded weight in assessing the remaining claims in issue, as they failed to consider claims 2 to 18 and 20 to 38.

[202] As well, Plaintiff's counsel established during cross-examination of the Defence experts that excerpts and documents between their respective reports were equivalent, and were chosen by and discussed with counsel. For instance, only two of the nine documents Dr. Dutcher referred to in his report were found by him, with the remaining seven having been provided by counsel.

[203] Undoubtedly, consultation and collaboration between expert witnesses and counsel is a necessary component of litigation, particularly in highly technical cases (*Moore v Getahun*, 2015 ONCA 55, at paras 55-66). Nonetheless, I share Justice Barnes' concern as expressed in *Astrazeneca Canada Inc v Apotex Inc*, 2015 FC 322, regarding the approach taken by experts in assessing prior art. Experts are expected to conduct their *own* prior art searches, and not simply rely on documents provided by counsel. As Justice Barnes explained at paragraph 231 of that judgment:

[a]n expert who carries out an obviousness analysis largely or solely on the strength of prior art references selected by retaining counsel runs a real risk of offering a hindsight opinion. A thorough prior art review necessarily includes a search for all of the available relevant literature whether it supports inventiveness or not. It requires consideration of relevant art in the larger context of other possible pathways to the patent solution or to ideas that point away from that solution.

[204] The experts' prevailing obligation is to maintain impartiality while fulfilling their proper role of assisting the Court, and the lack of independent research on the part of some experts in the present case has been considered in assessing the weight afforded their opinions on the issues of anticipation and obviousness.

[205] While the Defendants refer to some 33 references in their pleading as prior art (at least for obviousness), at trial they relied only on the four references outlined above for both issues of anticipation and obviousness, consisting of the IR Handbook, Electric IR Heating, Polymer Processing and the '624 Patent.

[206] For the below assessment of anticipation and obviousness, it must be kept in mind that since the filter claims are invalid, the only effective way the '376 Patent teaches the POSITA to eliminate wavelengths is via irradiation of IR radiation emitting wavelengths substantially around 1.2 um, otherwise characterized in the prior art as "short-wave" radiation. Although the claims above found to be inutile will not be considered in light of the prior art below, I have examined the claims found to be overbroad. Although I disagree with the Defendants' characterization of the invention as not including the vertical orientation aspect of the extrusion process, even had such claims not been found overbroad for failing to include vertical orientation, they were anticipated or obvious in light of the prior art.

(1) The IR Handbook

[207] The evidence revealed that the IR Handbook was consulted regularly by those in the field at the relevant time. This prior art reference discloses various aspects of the '376 Patent:

- a) It describes use of short wave radiation to heat plastics, which Defence experts find is analogous to the '376 process of removing wavelengths corresponding to absorption peaks – the '376 Patent simply describes the underlying physical phenomena occurring when irradiating certain plastics with short-wave IR radiation.
- b) Figures and explanations in the IR Handbook would allow a POSITA to determine that by irradiating with short-wave IR, there will be a corresponding reduction of radiation at wavelengths further from this peak, including at the 3 and 6 μm peaks (p 46).
- c) The IR Handbook also discloses the same special advantages of applying short-wave IR radiation to heat polymers as the '376 Patent, namely, rapid, uniform, heating without surface damage. For example, it states that short-wave IR is “absorbed deep down into the material and not only on the surface”, that “rapid heating right through the material is achieved”, and that “it is necessary to heat the entire material evenly” (see pp 48, 10, 28).
- d) The information on selection and operation of IR lamps would enable a POSITA to determine which to use for producing short-wave IR radiation. For instance, the IR Handbook describes that “IR lamps work at a nominal temperature of 2400 K and 3000 K ... this provides maximum intensity at wavelengths of 1.2 and 1.0 μm respectively” (p 6).

[208] I find on a balance of probabilities that the above-listed information provides the necessary disclosure such that the POSITA would understand what is being taught and would know the special advantages as described in the '376 Patent. The IR Handbook actually provides *more* detail regarding selection and operation of IR lamps than does the '376 Patent, and the skilled person would be able to carry out what is disclosed in claim 1 and 19 with minimal trial and error, such that by referring to the IR Handbook a POSITA would necessarily infringe those claims.

[209] Although the IR Handbook does not disclose the need to substantially reduce wavelengths at the absorption peaks of a polymer, as described in the '376 Patent, I agree with Dr. Boreman's opinion that such a characterization is simply an inevitable consequence of irradiating polymers with short-wave IR. The POSITA also does not actively eliminate wavelengths in the '376 invention: he or she radiates with 1.2 μm , and achieves that as a matter of course.

[210] The IR Handbook discloses the temperature of the IR lamp that provides maximum intensity at wavelengths of 1.2 μm (p 6). It also describes regulation of radiation power (p 10). Considering the evidence that the POSITA would refer to ASTM standards to determine the required degree of crosslinking, claim 22 is both disclosed and enabled.

[211] The IR Handbook describes the IR heater unit, explaining that it consists of a reflector body and a tubular IR lamp. Figure 10 on page 6 describes the different types of reflectors, which create either a parabolic or elliptical cross-section, and even provides further technical data for selection of reflectors. Accordingly, claim 32 is both enabled and disclosed.

[212] I also find that the IR Handbook anticipates claims 33 and 34. It discloses use of an IR lamp for radiation (claim 33) and also discloses examples of directed radiation, which exemplify the symmetrical arrangement of IR lamps around the irradiated material (claim 34) (IR Handbook, p 11). The information provided in the IR Handbook is sufficiently enabling, and indeed more detailed than the '376 Patent.

[213] Thus, I find that the IR Handbook anticipates claims 1, 19, 22, 32, 33 and 34.

[214] I also find that this reference, when considered alongside the '624 Patent, renders many of the claims of the '376 Patent obvious, as discussed below.

(2) Electric IR Heating

[215] Electric IR Heating mentions that selection of the appropriate wavelength is particularly important for processing plastics, such as polyethylene, as most thermoplastic polymers have similar but selective absorption characteristics. It states that “medium or short wave will penetrate plastic more readily and therefore reduce the possibility of scorching the surface” (p 105), and it also describes that short-wave tubes operate at a temperature of 2200 °C, “corresponding to a peak wavelength of 1.2 microns” (p 41). However, the reference does not direct or enable a POSITA to know which wavelengths in the mid or short-IR range to select for plastics heating, and more than simple experimentation would be required to determine the appropriate wavelength.

[216] The disclosure in Electric IR Heating is insufficient to anticipate any claims of the ‘376 Patent.

(3) Polymer Processing

[217] Although Polymer Processing discloses elements of the key teaching of the ‘376 invention as claimed in claim 1, it does not disclose all of its elements, nor meet the test of enablement.

[218] Some special advantages are described: the text states, with regard to heating a semi-transparent material, such as polyethylene terephthalate [PET] (p 118):

there are advantages in having the polymer partially transparent to the incident radiation because the radiation is absorbed internally in the polymer sample, which provides a more uniform heating of

the material relative to that produced when radiation is absorbed only at the surface.

[219] Figure 5.17 of the text displays the absorption spectra for a 3.8 mm thick sheet of PET, which depicts the radiation curves at various emitter temperatures. Although a POSITA would be able to determine from Figure 5.17 the high areas of IR transmittance, and thus where along the IR spectrum a polymer would be “partially transparent” to the incident radiation, I find that Polymer Processing does not direct use of short-wave IR radiation, or provide any reference to the 1.2 μm value disclosed in the ‘376 Patent. Some experimentation and trial and error would be necessary.

[220] Moreover, Polymer Processing, while conveying a similar principle to the teachings of the ‘376 Patent, is not directive and cannot be said to “contain so clear a direction that a POSITA would in every case and without possibility of error be led to the claimed invention” (*Beloit Canada Ltd v Valmet-Dominion Inc (CA)*, [1997] 3 FC 497 (FCA) at para 29 [*Beloit*]).

[221] Even if disclosure were adequate, I also do not find that this prior art reference provides sufficient information to enable a POSITA to make or use the ‘376 invention as disclosed.

(4) The ‘624 Patent

[222] The ‘624 Patent teaches crosslinking of a polymer-coated cable by simultaneous application of IR radiation and pressure in a vulcanization tube. It explains that the polymer must have “good perviousness” to the radiation, which according to Defence experts, is equivalent to the supposed inventive concept of claims 1 and 19 of the ‘376 Patent.

[223] The '624 Patent also discloses the same special advantages as taught in the invention of the '376 Patent, namely "through-heating" and "crosslinking through the cross-section" (column 4, lines 6-8), "rapid heating" and "rapid cross-linking" (column 1, lines 66-68). It does not mention good surface finish.

[224] Although the '376 Patent states much of it is "quite conventional", and the '624 Patent and '376 Patents share various parallel features and disclose a similar invention, I do not find that the '624 Patent anticipates the '376 Patent. This is because the claimed invention of the '376 Patent is directed to a use (in general, cross-linking polymers, and in particular, the manufacture of polyethylene tubes using vertical orientation in the extrusion process) different from that previously disclosed and enabled in the '624 Patent (applying insulation of crosslinked polymer on a cable conductor by simultaneous application of heat and pressure in a vulcanization tube) (*Abbott Laboratories*, above, at para 75). Furthermore, the essential feature of using a vertical orientation in order to achieve the benefits of the '376 Patent is neither disclosed, nor enabled in the '624 Patent.

E. *Obviousness*

[225] The four-part test for obviousness was set down by the Supreme Court of Canada in *Sanofi*, above, at para 67:

It will be useful in an obviousness inquiry to follow the four-step approach first outlined by Oliver L.J. in *Windsurfing International Inc. v. Tabur Marine (Great Britain) Ltd.*, [1985] R.P.C. 59 (C.A.). This approach should bring better structure to the obviousness inquiry and more objectivity and clarity to the analysis. The *Windsurfing* approach was recently updated by Jacob L.J. in *Pozzoli SPA v. BDMO SA*, [2007] F.S.R. 37, [2007] EWCA Civ 588, at para. 23:

In the result I would restate the *Windsurfing* questions thus:

(1) (a) Identify the notional "person skilled in the art";

(b) Identify the relevant common general knowledge of that person;

(2) Identify the inventive concept of the claim in question or if that cannot readily be done, construe it;

(3) Identify what, if any, differences exist between the matter cited as forming part of the "state of the art" and the inventive concept of the claim or the claim as construed;

(4) Viewed without any knowledge of the alleged invention as claimed, do those differences constitute steps which would have been obvious to the person skilled in the art or do they require any degree of invention?

[Emphasis added.]

It will be at the fourth step of the *Windsurfing/Pozzoli* approach to obviousness that the issue of "obvious to try" will arise.

[226] The Supreme Court found that the "obvious to try" test is appropriate in areas of endeavour where advances are often gained by experimentation, and where numerous interrelated variables affect the desired result (*Sanofi*, above, at para 68). On the evidence before me – that it would be routine for a POSITA to run standard experimentation by setting up a line to run the process, using trial and error to obtain the desired results – the obvious to try considerations apply in this instance. Accordingly, the Court is also to be cognizant of the following non-exhaustive factors in discerning whether the '376 invention would have been obvious to a POSITA at the relevant time (*Sanofi*, above, at para 69):

- a) Is it more or less self-evident that what is being tried ought to work? Are there a finite number of identified predictable solutions known to persons skilled in the art?
- b) What is the extent, nature and amount of effort required to achieve the invention? Are routine trials carried out or is the experimentation prolonged and arduous, such that the trials would not be considered routine?
- c) Is there a motive provided in the prior art to find the solution the patent addresses?

[227] I agree with the Plaintiff that obviousness remains a difficult test to meet, and that it is still necessary to show that the skilled person would have come directly and without difficulty to the invention – hindsight is 20-20, and measuring references to find an invention “obvious” should be scrutinized carefully by the Court (*Bridgeview Manufacturing Inc v 931409 Alberta Ltd (cob Central Alberta Hay Centre)*, 2010 FCA 188 at paras 50-51; *Sanofi*, above, at para 85).

[228] As also stated by Justice Snider for guidance in *Sanofi-Aventis Canada Inc v Apotex Inc*, 2009 FC 676 at para 267, aff'd 2011 FCA 300:

As expressed by Justice Rothstein in *Sanofi-Synthelabo*, obviousness of the "invention" is to be measured. However, it appears to me that the assessment must be focused on the "inventive concept of the claim in question" and not to some larger "invention" that might be described in the specification of the patent. Otherwise, we would have the illogical result that a finding of obviousness could invalidate all of the claims in a patent and not just those in issue. Thus, I will proceed with my analysis on the basis that the "invention" or "inventive concept" being examined is limited to those "inventions" as identified by Claims 1, 2, 3, 6 and 12.

[229] In applying the *Sanofi* test, I find that the differences that exist between the '624 Patent and '376 Patent, for the specific claims described below, constitute steps that would have been obvious to a POSITA at the relevant time in light of their common general knowledge. I say this bearing in mind the test is that for an invention to be “obvious to try” the evidence must convince the court on a balance of probabilities that it was more or less self-evident to try to obtain the

invention (*Sanofi*, above, at para 66; *Eli Lilly Canada Inc v Mylan Pharmaceuticals ULC*, 2015 FCA 286).

[230] The '624 Patent's application to polymer crosslinking in the cable industry is not sufficiently disparate to render its application to the polymer processing, or even to the tube manufacturing industries inventive. There is evidence that the cable industry provided the "impetus behind development of various crosslinking processes" (Seydel Report, Tab G, p 490) and that a POSITA at the relevant time could and may well have referred to crosslinking plastic methods in the cable industry to solve the problems addressed by the '376 Patent (Dr. Palermo Cross-Examination).

[231] As well, it must be remembered that the POSITA for the '376 Patent at the relevant date has knowledge of polymer processing and extrusion of polymer products *generally*, not only in relation to extruded tubes, and is familiar with IR radiation and crosslinking apparatus.

[232] I find it persuasive that a POSITA, at the relevant time, looking to rapidly heat and uniformly crosslink polymers to solve the problems described in the '376 Patent, would reasonably consider and be expected to know prior art references related to polymer processing in the cable industry, including the '624 Patent, which describes crosslinking polymers using convective/radiative heating. Although the invention in the '376 Patent finds particular application in pipe manufacture, the relevant field at issue in considering the common general knowledge required for the '376 Patent broad claims 1 and 19 is polymer processing, not pipe manufacture specifically.

[233] In assessing obviousness, the issue is the nature and extent of the difference between the invention and what has been disclosed in the prior art or prior use in the relevant industrial field. In my view, there is little, if any, inventive step by a POSITA who considers the '624 Patent, along with the IR Handbook (commonly referenced by those in the field), and applies the teachings of the two references to polymer processing generally. In other words, in reading the '624 Patent alone or together with the IR Handbook, in light of the POSITA's common general knowledge as of the relevant date, many of the claims of the '376 Patent would have been more or less self-evident to try by the POSITA (*Sanofi*, above, at para 66).

[234] The '624 Patent renders obvious claims 1 and 19. It requires that the polymer used must have "good perviousness for the radiation at the temperature for the extrusion and cross-linking" (column 2, lines 22-24). Both of the Defendants' experts opined that a POSITA would consider that this discloses the same information as the '376 Patent; namely that the wavelengths corresponding to absorption peaks of the polymer material be eliminated to achieve the articulated benefits of irradiated heating.

[235] I agree with this construction, as the POSITA has a basic understanding of how to calculate IR absorption profiles of different polymer material, and would know that "good perviousness" indicates the polymer must be irradiated with wavelengths it transmits, rather than absorbs (i.e. that the wavelengths corresponding to absorption peaks are eliminated). As above described in assessing anticipation, the IR Handbook also makes obvious these claims.

[236] The '624 Patent also specifically directs that to crosslink polyethylene, it is to be heated using an IR lamp emitting a peak wavelength of 1.2 μm . This coincides with the information conveyed in the IR Handbook. The evidence of Dr. Kimmel discloses that the claimed elimination of the '376 Patent will necessarily occur by irradiating polyethylene with this wavelength. Thus, the '624 Patent and the IR Handbook also render obvious process claims 11, 12 and 13 (as they depend from 9, 10, 11 or 12) and apparatus claims 33 and 38, which require irradiation with wavelengths outside certain micron ranges, and which specifically direct irradiating the polymer using an IR lamp with a wavelength substantially located around 1.2 μm .

[237] The '624 Patent and IR Handbook also render obvious the invention described in claims 4, 5, 6, 29, 30 and 31 of the '376 Patent. In the '624 process, the "radiation which passes through the polymer is reflected back towards the polymer" (claim 4, '376 Patent). Dr. Kimmel's evidence was that the carbon black layer, lining the inner polymer surface in the '624 process, reflects IR at the frequencies it most absorbs. Radiation passing through the polymer, and being "re-radiated" back through the polymer would signify to a POSITA that the radiation is "reflected back towards the polymer" as in the '376 Patent. Dr. Kimmel in fact testified that the inner carbon layer would have the same scientific effect on the radiation as the aluminum later in the '376 Patent. In my view, there is no inventive step to apply this same principle to pipe, rather than cable, extrusion.

[238] The '624 Patent does not mention that the reflective layer consists of a mirror having a parabolic or elliptical cross-section (claim 32), nor does it describe the specific arrangement of

the IR lamps (claim 34), yet such exact positioning was disclosed in the IR Handbook (pp 6, 11), was “conventional”, and would have been obvious to a POSITA at the relevant time.

[239] Moreover, the ‘624 Patent describes polyethylene as an example of a suitable polymer (column 2, lines 24-25) and teaches that organic peroxides are used to effect the crosslinking (column 1, lines 11-12; column 2, lines 30-31). I find that even notwithstanding the dependencies which affect the validity of claim 8, both claims 8 and 9 would have been obvious to a POSITA at the relevant time. Although the ‘624 Patent describes LDPE (column 3, line 46), Dr. Palermo testified that high, medium and low-density polyethylene (HDPE, MDPE and LDPE) would all have similar absorption peaks and I find the ‘376 Patent sufficiently general that the claimed invention would also apply to crosslinking LDPE.

[240] Application of nitrogen or another inert gas to the extruded polymer cable-coating is also described in the ‘624 Patent (column 2, line 67 – column 3, lines 1-2), and the evidence shows that it was commonly used to prevent oxidation during extrusion processes. There is nothing inventive regarding its use in the ‘376 Patent, and claims 14, 24 and 28 would have been self-evident to a POSITA.

[241] The ‘624 process also discloses continuous extrusion of the polymer-coated cable through the IR zones; claim 15 is obvious.

[242] Claim 22 describes the apparatus in which the power of the IR zones is regulated to achieve the desired degree of crosslinking. The ‘624 Patent directs that the temperature of the IR

lamps operate at 2100 °C, thus providing radiation with wavelengths of 1.2 µm (column 3, lines 50-55) – this constitutes regulation of the IR zones. The IR Handbook also provides information on selection and operation of IR lamps and describes the temperatures that provide a maximum intensity of IR radiation at wavelengths of 1.2 and 1.0 µm respectively (p 6). Although the ‘624 Patent and other references do not indicate a desired degree of crosslinking, evidence at trial indicated the ASTM standards not only suggest but require that a POSITA understand the requisite degree of crosslinking to be achieved.

[243] The ‘624 Patent and the other prior art references relied on by the Defendants at trial do not specifically indicate the means for feeding the crosslinkable polymer material through the IR zones, as set out in claim 23 of the ‘376 Patent. Nor is there mention of an extruder being placed before the IR zone, as in claim 35. However, the POSITA has the common general knowledge of polymer processing and extrusion of polymer products at the relevant date, and of IR apparatus used for crosslinking. The ‘376 Patent admits much of the invention is “quite conventional” and I do not find either of these claims involves inventive ingenuity.

[244] Thus, in summary, I find that the ‘624 Patent and the IR Handbook render obvious the following process and apparatus claims of the ‘376 Patent. In my view, the ‘376 invention would have been more or less self-evident to try and a POSITA at the time, in light of the state of the art of the common general knowledge as at the claimed date of the invention, would have come directly and without difficulty to the solution taught by the following claims of the ‘376 Patent:

- a) Process claims: 1, 4, 5, 6, 9, 11, 12, 13, 14, 15;
- b) Apparatus claims: 19, 22, 23, 24, 28, 29, 30, 31, 32, 33, 34, 35, 38.

[245] However, I also find that the '624 Patent and the three other prior art references relied upon by the Defendants do not teach, nor render obvious, the subject matter of the following claims of the '376 Patent:

- a) Claim 10: That the crosslinking additive consists of azo-compounds.
- b) Claim 20: None of the prior art references relied upon mention that the IR zone consists of part of a forming tool, made of material transparent to IR radiation.
- c) Claims 16, 17, 18 and 25-28 relate to vertical orientation of the IR zones, and are not alluded to in the '624 Patent, or in the other prior art references analyzed. I do not find the claims obvious in light of these references.

[246] I note that there is reference within one of the prior art documents, *Plastics Extrusion Technology* (1988), produced in Mr. Seydel's Report (Exhibit G, p 499) and entered as evidence, to the use and benefits of vertical orientation of extrusion lines in the context of steam crosslinking processes for sheathed cable. The reference describes the same advantages as the '376 Patent; that the deformation of the uncrosslinked extruded cable by gravity forces is negligible, and the process is contactless.

[247] Mr. Seydel opined that this reference would have made obvious the vertically oriented manufacturing process for pipe in the '376 Patent. Not only have I afforded his opinion little if any weight, but I disagree. There are sufficient differences between the steam crosslinking vertical configuration and that described in the '376 Patent. In the steam process, the polymer coating of the cable is not crosslinked in both directions, and the text describes that such vertical lines are about 75 meters high and require appropriate tower-like buildings. The '376 process and apparatus, by having the PEX pipe deflected 180° by the wheel at the top, avoids this problem. As well, the '376 configuration crosslinks the polymer in both directions using IR radiation.

[248] Dr. Kimmel testified that the skilled person in 1995 knew that gravity forces have a reduced effect on deformation of a just-extruded material travelling in a vertical rather than horizontal orientation. As well, Dr. Palermo testified that having the extruded tube travel up and then down is a straightforward, efficient and logical design choice. However, all of the prior art addressing extruded pipes used horizontal heating, and the steam-process did not crosslink in both directions. Simplicity does not negate invention, and the evidence has not explained, directly or by implication, why the vertical orientation and apparatus as described in the '376 Patent was not discovered or used by others for IR heating of polymers, or pipe extrusion processes previously (*Janssen-Ortho*, above, at para 113; *Bayer AG v Apotex Inc*, 2007 FCA 243 at para 25).

[249] The '624 Patent's relevance to the POSITA for the '376 invention, despite its application to the cable industry, derives from the inventions' otherwise highly analogous features. The broad application of the '376 invention, which is not limited to pipes, does not remedy the numerous differences between the vertical extrusion process as described in the '376 Patent and in *Plastics Extrusion Technology*. I do not find this reference would have made obvious, or obvious to try the vertical orientation as described in the '376 Patent.

[250] While the Defendants maintained that all claims, 1-50, of the '376 Patent were invalid, no evidence was led regarding the validity of any claims above 38. Given claims 39-50 are not at issue for infringement, and my finding that some of the claims of the '376 Patent alleged to be infringed are valid, there is no need to be decide validity of claims not in issue and on which no evidence was led.

[251] In conclusion, according to the above analysis, the following claims of the '376 Patent remain valid, and are at issue for infringement:

- a) Process claims: 16 (as it depends from claims 9-15), 17;
- b) Apparatus claims: 25 (as depends from 19, 22-24), 26, 27.

VII. Expert Witness Evidence on Infringement

[252] Although only the above claims are valid, the expert evidence on infringement relating to claims upon which these valid claims depend remains relevant.

A. *Plaintiff's Expert Witnesses*

(1) Dr. Gene Palermo

[253] Dr. Palermo found that all of the elements of claims 1 and 19 of the '376 Patent are present in Pexcor's manufacturing process and the apparatus used therefor. Pexcor's PEX pipe is a "polymer material", being made of 99.0% HDPE, and Pexcor uses IR radiation as the heat source in its manufacturing process.

[254] The ovens used by Pexcor (and provided by Crosslink) have IR zones, each comprised of four inward-facing Solaronics monocassettes, containing IR lamps. The IR zones are operated (upon recommendation by Crosslink) at power levels of 60-75%, with a target temperature of 1372 °C, such that the peak intensity of IR radiation emitted is in the range of 1.5-1.7 μm .

[255] The skilled person would know that the characteristic curve of emitted IR radiation declines in intensity further from its peak at 1.5-1.7 μm . Thus, in Pexcor's process, the IR radiation applied to the polymer pipe at polyethylene's absorption peaks is substantially reduced,

amounting to “elimination” of the wavelengths corresponding to the absorption peaks for polyethylene.

[256] Pexcor’s process also infringes other dependent claims of the ‘376 Patent. It irradiates polyethylene using wavelengths outside the ranges 3.3-3.6 μm and 6.7-6.9 μm , and outside the range 2-10 μm . As well, a substantial amount of the IR radiation emitted in Pexcor’s process is located around 1.2 μm . This analysis is based upon the curve of IR source temperature versus wavelength, which shows that approximately 66% of IR radiation relative to the peak is reduced at 1.2 μm in the curve corresponding to the temperature of 1327 $^{\circ}\text{C}$.

[257] Some of Pexcor’s products are flushed with nitrogen to prevent oxidation during crosslinking, which would reach the inner surfaces of the pipe. As well, the extrusion and feeding of pipe through the IR zones in Pexcor’s process is continuous.

[258] Dr. Palermo finds that claims 16, 17, 25, 26 and 27, relating to vertical orientation of the IR zones (the claims which remain valid), are also infringed in Pexcor’s process and apparatus. The Key West video of Pexcor’s extrusion line shows that following extrusion, pipes are fed vertically upwards, around an upper turning wheel and travel vertically downwards through eight IR zones.

(2) Dr. Robert Kimmel

[259] Dr. Kimmel reviewed and described Pexcor's process and apparatus to manufacture PEX pipe, as outlined above at paragraphs 26 and 27 of this judgement. In his view, akin to that of Dr. Palermo, Pexcor infringes all of the process and apparatus claims at issue.

[260] Despite Dr. Kimmel's opinion that Pexcor's use of an IR source substantially around 1.2 μm amounts to "substantial reduction" and thus infringement of the '376 Patent, on cross-examination, Dr. Kimmel agreed that various factors affect operation of the IR lamps and the effective radiation they release, such as the type of lamp and length of filaments. The '376 Patent does not specifically indicate the type of lamp, or length of the filament: it only provides an example that lamps having wavelengths of about 1.2 μm could be used as sources for IR radiation ('376 Patent, page 9, lines 37, 38).

[261] Dr. Kimmel stated that some trial and error is required to determine if infringement has occurred: one must determine the degree of crosslinking and examine the surface finish properties. In his opinion, it would be routine for a POSITA to run standard experimentation by setting up a line to run the process, using trial and error to obtain the desired results, notwithstanding the expense to do so.

B. *Defendants' Expert Witnesses*

[262] Dr. Boreman admitted to have based his opinion with respect to anticipation, obviousness and infringement only on claims 1 and 19 and he did not consider any other claims. These claims

have been invalidated on the basis of overbreadth, as well as obviousness and anticipation, and thus Dr. Boreman's opinion on the issue of infringement is not necessary.

[263] Similarly, Dr. Dutcher admitted his infringement analysis only assessed claims 1 and 19, and is more limited than the other experts' reports. I agree. For the above reasons regarding why Dr. Boreman's opinion is irrelevant to the present infringement analysis of the remaining valid claims, I also conclude the same for Dr. Dutcher.

VIII. Infringement Analysis

[264] The only claims of the '376 Patent which remain valid and are alleged to be infringed by Uponor are the claims relating to vertical extrusion through the IR zones: process claims 16 and 17 and apparatus claims 25, 26 and 27.

A. *Pexcor*

[265] The evidence before the Court establishes that Pexcor carries out a process to make, use and sell extruded PEX pipe. Pexcor irradiates the polymer material (HDPE combined with an organic peroxide), with IR radiation such that the most significant absorption peaks of polyethylene, at 3.3-3.6 μm and 6.7-6.9 μm , are substantially reduced, or in terms of the '376 Patent as properly construed, "eliminated".

[266] I largely agree with Dr. Palermo's infringement analysis in respect of the remaining valid claims at issue.

[267] The Key West video footage of Pexcor's manufacturing line in evidence demonstrates that in the Pexcor process, the pipe is extruded horizontally and directed 90° where it travels vertically up through four IR crosslinking zones (claims 16, 25, 26). At the top of the oven, the pipe is redirected 180° around a wheel, and subsequently travels downward through four more IR zones (claims 17, 27). This is confirmed by the read-in discovery evidence of Pexcor and Heatlink's representatives.

[268] In reviewing the evidence and features of the Pexcor manufacturing process and apparatus used in Canada, I find claims 16, 17, 25, 26 and 27 of the '376 Patent infringed.

B. *Heatlink*

[269] Heatlink sells and distributes PEX pipe manufactured by Pexcor's infringing process. Given my finding that Pexcor has infringed the '376 Patent, Heatlink is likewise liable for selling the PEX pipe made using an infringed patented process and apparatus.

C. *Crosslink*

(1) Direct

[270] There is no evidence of direct infringement by Crosslink. While Crosslink sold IR ovens to Pexcor, these ovens were sold freight-on-board [FOB] in Finland, and therefore there was no direct making, using or selling any of the patented '376 apparatus or carrying out of the '376 patented process by Crosslink in Canada (*Beloit*, above).

(2) Indirect (Inducing)

[271] As a preliminary argument, Crosslink takes the position that it has no liability for any alleged activities falling outside the six year limitation period (*Patent Act*, s.55.01; *Federal Courts Act*, RSC 1985, c f-7, s.39(2)). Since this action was commenced on March 21, 2011, Crosslink submits that no action lies for any alleged infringing activities prior to March 21, 2005. This includes any claim for inducing infringement as alleged against Crosslink.

[272] Though unfortunate to preclude success of this argument on a procedural basis, Crosslink cannot rely on a limitation defence disentitling Uponor to relief in the present case – notwithstanding that eleven years passed from when Crosslink sold its first oven to Pexcor and the commencement of this action – as Crosslink did not plead any limitation defence (*Merck & Co v Apotex*, 2006 FC 524 at para 173, rev'd on other grounds 2006 FCA 323; *Federal Courts Rules*, SOR/98-106, s.183(c)).

[273] The Plaintiff's fact and expert witnesses provided no evidence regarding Crosslink's liability for induced infringement. Thus, evidence of inducement by Crosslink must arise from the read-ins from discovery admitted at trial.

[274] The test for inducing patent infringement was most recently articulated by the Federal Court of Appeal in *Weatherford Canada Ltd v Corlac Inc*, 2011 FCA 228 at para 162

[*Weatherford*]:

It is settled law that one who induces or procures another to infringe a patent is guilty of infringement of the patent. A determination of inducement requires the application of a three-

prong test. First, the act of infringement must have been completed by the direct infringer. Second, the completion of the acts of infringement must be influenced by the acts of the alleged inducer to the point that, without the influence, direct infringement would not take place. Third, the influence must knowingly be exercised by the inducer, that is, the inducer knows that this influence will result in the completion of the act of infringement: *Dableh v Ontario Hydro*, [1996] 3 FC 751, paras 42, 43 (CA), leave to appeal refused, [1996] SCCA No 441; *AB Hassle v Canada (Minister of National Health and Welfare)*, 2002 FCA 421, 22 CPR (4th) 1, para 17 (CA), leave to appeal refused, [2002] SCCA No 531; *MacLennan v Les Produits Gilbert Inc.*, 2008 FCA 35, 67 CPR (4th) 161, para. 13. The test is a difficult one to meet.

[275] To succeed in proving inducement of infringement of the '376 Patent by Crosslink, the Plaintiff has the onus of proof, and must prove all of the following elements:

- a) one or both of the Heatlink Defendants must have directly infringed the '376 Patent in Canada;
- b) Crosslink must have influenced the actions of at least one of Heatlink or Pexcor to the point that, without the influence of Crosslink, direct infringement would not take place;
- c) Crosslink must have known that its influence would result in the completion of at least one act of infringement of the '376 Patent by at least one of Heatlink or Pexcor.

[276] The first part of this test has clearly been satisfied: Pexcor and Heatlink have directly infringed the valid claims of the '376 Patent.

[277] Regarding the second prong of the test, it is well established that it is not an infringement to manufacture or sell a component intended to be used for the purpose of infringing a patented process, without more. This is so even if the alleged inducer has actual knowledge of a component's ultimate use as an infringement. Such activity becomes inculpatory when the seller indicates to its clients the use to be made of the component, and makes "its clients aware of the fact that its product is intended to work the patented invention, which is the only reason they are

buying it” (*MacLennan v Gilbert Tech Inc*, 2008 FCA 35 at para 40). Simply put, the inducer must actively do something leading the direct infringer to infringe.

[278] The Plaintiff submits that “but for” Crosslink’s activities, Pexcor would not have directly infringed the patented process and apparatus. Crosslink provided continuing advice, instructions, warranties, service and training to Pexcor such that Pexcor was able to achieve the required standard of crosslinking and successfully manufacture PEX pipe.

[279] Furthermore, the Plaintiff contends the situation is not analogous to *Slater Steel Industries Ltd v R Payer Co* (1968), 55 CPR 61 (Ex Ct), in which a power imbalance between the parties led the Exchequer Court to conclude that a “one-man show” could not have induced a “giant power entity” or Government agency to infringe the patent at issue. The Plaintiff submits that Pexcor was not a sophisticated or experienced entity in the PEX manufacturing business, and that they were wholly reliant upon Crosslink to carry out the patented process using the Crosslink ovens.

[280] In terms of Crosslink’s “influence” over Pexcor and Heatlink, the evidence establishes that:

- a) between 2000 to 2012, Crosslink sold to Pexcor IR crosslinking ovens for the purpose of manufacturing PEX pipe;
- b) Mr. Gary Schmidt stated he obtained information regarding polyethylene’s absorption peaks and peroxide from Mr. Heino, and also from Pexcor’s own research;
- c) Mr. Heino went to Pexcor’s facilities with an electrician to advise on the first oven’s use – they did not produce pipe with optimized crosslinking density or other properties at that time;
- d) Crosslink’s subcontractor attended Pexcor’s facility to install and interface the software of the crosslinking ovens with Pexcor’s equipment, and Crosslink provided assistance and ongoing advice to Pexcor personnel on how to operate the Crosslink ovens;

- e) Crosslink entered into a written agreement dated March 30, 2001, which included a warranty that Crosslink is exclusive owner of a pipe patent (PCTF199/00570) and that Crosslink will make arrangements for construction and assembly of ovens to produce pipes based on the patent;
- f) From 2005 to the present, various of the crosslinking ovens were modified by Crosslink's subcontractor;
- g) Crosslink gave Pexcor several instructive documents, including electrical drawings, the IR Handbook (which Pexcor used to operate and optimize the Crosslink ovens), photos, a manual pertaining to monocassettes, and a powerpoint presentation regarding the manufacturing process of PEX A pipe;
- h) Crosslink directed Pexcor to set the power of the crosslinking oven at a power range of 65 to 85% to obtain the desired degree of crosslinking (70%, as required by ASTM standards);

[281] Although Crosslink evidently provided involved support to Pexcor, commencing with sale of the first oven, I do not find the evidence is sufficient to prove that Pexcor and Heatlink's direct infringement would not have taken place without Crosslink's influence. Partial responsibility is not enough.

[282] Moreover, while Mr. Heino initially directed Pexcor to set the power levels of the IR lamps in the crosslinking ovens at 65% to 85%, his discovery evidence was that the power level of the ovens depends on a variety of factors such as pipe thickness and the speed of the pipe's journey through the oven, which expert evidence conveyed depends on the type and setting of extruder being used. There is not simply one power, and even the power of the IR lamps in different zones can vary and can be set for differing functions.

[283] Mr. Heino also stated he had advised Pexcor that all IR lamps be set to the same level, as a "starting point", but that the customer, in this instance Pexcor, through trial, error and experimentation, learns how to optimize the power settings in different units to achieve the desired result (P-11, p 51).

[284] The '376 invention has various components: it involves using the correct polymer and peroxide, extrusion, application of nitrogen (etc.) and of course, irradiation with IR such that the wavelengths corresponding to the polymer in question have been "eliminated" within the meaning of the patent. The only portion of the '376 invention in which Mr. Heino is specialized, and upon which he instructed Pexcor, is crosslinking the pipe once it has been extruded. There are simply too many variables to the successful execution of the patented process to find that without Crosslink's influence, Pexcor would not have infringed the '376 Patent.

[285] It is well established that there is no infringement of a patent in selling an article that does not in itself infringe the patent even when the vendor knows that the purchaser buys the article for the purpose of using it in the infringement of the patent (*Beloit*, above, at para 16, citing *Beloit Canada Ltée/Ltd v Valmet OY*, [1988] FCJ No 103 at para 30 (FCA), leave to appeal to SCC refused, 1988 CarswellNat 1494 (WL)).

[286] Furthermore, I have difficulty with the proposition that by Crosslink responding to a purchase request from a customer (Pexcor/Heatlink) and supplying one of the, albeit significant, components of the '376 apparatus, this translates into Crosslink having exercised sufficient influence over Pexcor and Heatlink to constitute inducement to the point that, without their influence, direct infringement of the '376 process and apparatus would not have taken place.

[287] Since I have not found that the second part of the *Weatherford* test has been proven, there is no need to consider whether Crosslink knew that its influence would result in the completion of at least one act of infringement of the '376 Patent by at least one of Heatlink or Pexcor.

[288] Likewise, given that the evidence failed to establish that Crosslink met the stringent test for inducing infringement, there is also no need to reflect upon the Plaintiff's allegation that Pexcor's on-going direct infringement is caused by the continuum of Crosslink's root inducing acts.

D. *Laches and Acquiescence*

[289] The Defendants, Heatlink and Pexcor, also allege that Uponor is guilty of laches and acquiescence by failing to bring this action until March 2011, over at least six years, if not longer, from learning of the Defendants' alleged infringement in Canada of the '376 Patent.

[290] The doctrine of laches does not apply to legal remedies where there is a statutory limitation period and the Plaintiff commenced its claim within that period (*Remo Imports Ltd v Jaguar Cars Ltd*, 2005 FC 870 at paras 51-52 [*Remo*]). In the case of an action for patent infringement, the relevant limitation on the amount of damages that can be recovered under section 55.01 of the *Patent Act* is 6 years:

55.01 No remedy may be awarded for an act of infringement committed more than six years before the commencement of the action for infringement.

[291] As well, although there is evidence suggesting that the Plaintiff was aware that Pexcor and Heatlink may have been infringing the '376 Patent since at least September of 2005, "a patentee is not required to sue at the first drop of the hat" (*Eurocopter v Bell Helicopter Textron Canada Ltée*, 2012 FC 113 at para 401, aff'd *Bell Helicopter, FCA*, above, citing *Sandvik AB v Windsor Machine Co* (1986), 8 CPR (3d) 433 (Fed TD) at page 443).

[292] To show acquiescence, there are four requirements:

- a) something more than mere delay is required and silence alone is not sufficient to bar a proceeding;
- b) the rights holder must know of its right and know of the other party's breach of that right;
- c) the rights holder must encourage the other party to continue the breach; and
- d) the other party must act to its detriment in reliance upon the encouragement by the rights holder.

Remo, above, at para 53.

[293] The Defendants have asserted delay in Uponor's commencement of this action. There is no evidence on the record that Uponor encouraged the Defendants to continue any breach of their patent rights, or that the Defendants relied upon that encouragement to their detriment.

[294] Pexcor and Heatlink's allegations of laches and acquiescence are inapplicable on the present facts, and provide them no defence.

E. *Unclean Hands*

[295] There is no evidence before the Court to sustain the Defendants' allegation of unclean hands.

IX. Remedies

[296] On August 4, 2015, Prothonotary Aalto issued a Bifurcation Order, on consent. The terms of that Order were that the issues respecting the validity and infringement of Canadian Patent No. 2,232,376 and the remedies – including declaratory relief, injunctive relief and delivery up, and any entitlement to damages or an accounting of profits – be determined separately from and prior to quantification issues.

[297] Since I have held claims 16, 17, 25, 26, and 27 of the '376 Patent valid and infringed by Pexcor and Heatlink (with specific dependencies), the Plaintiff is entitled to a declaration to that effect.

[298] Claims 1, 2, 3, 4, 7, 8, 9, 11, 12, 13, 14, 15, 19, 22, 23, 24, 29, 30, 32, 33, 34, 35, 36, 37, and 38 of the '376 Patent are invalid for lack of utility, insufficient disclosure, for being broader than any invention made or disclosed, and for anticipation and/or obviousness, for the reasons provided above.

[299] The Plaintiff has failed to prove that Crosslink either directly or indirectly has infringed or infringes the '376 Patent.

[300] I do not find the Plaintiff is entitled to delivery up based on the facts of this case. I do find that the Pexcor and Heatlink Defendants (and any subsidiary and affiliated companies, franchisees, officers, directors, employees, agents, licensees, successors, assigns and any other over whom they have control) are enjoined from manufacturing, using, offering for sale and/or selling to others for their use the apparatus for heating polymer material that infringes the '376 Patent and the PEX pipe made therefrom until expiry of the '376 Patent.

[301] The Plaintiff, Uponor AB, does not sell any of the PEX pipe it produces in Canada or North America – the two countries where Pexcor's PEX pipe is sold. As well, the evidence is that none of Uponor's North American companies (not named as plaintiffs) use the '376

invention, nor do they plan to. Instead, they employ the Engel Method or a modification thereof, which is in the public domain, to produce PEX pipe.

[302] This begs the question whether the '376 Patent is an improvement over the Engel Method such that it has resulted in any real commercial success. The evidence demonstrates that the '376 patented process and apparatus were not commercialized until well over 10 years following its development, and that other than limited use in two of Uponor's PEX manufacturing plants, in Sweden and in Poland, the Uponor Group of companies does not use the '376 patented technology.

[303] Despite my finding that a few claims of the '376 Patent remain valid and are infringed, if anything, the evidence shows that the '376 Patent was really only a slight improvement on the existing technology for polymer processing.

[304] However, I do not feel I can properly dismiss any entitlement to damages on the part of the Plaintiff, without the Plaintiff having the benefit of attempting to show evidentiary proof of those damages on a reference after trial, pursuant to the bifurcation Order. Thus, the quantum of the Plaintiff's damages arising from Pexcor and Heatlink's infringement will be left for a determination on issues of quantification.

[305] To be entitled to an accounting of profits, the Plaintiff must show some basis for the exercise of equity (*Janssen-Ortho*, above, at para 132). In the instant case, the Plaintiff has shown none, and I will not award the requested election of profits.

[306] Further, I find no basis whatsoever for the Plaintiff's claim for aggravated, punitive and exemplary damages.

[307] In the event of any monetary award of damages, pre-judgment interest is allowed. It should not be compounded. The rate of such interest should be calculated separately for each year since the infringing activity began, defined as the date of Pexcor's first commercially successful manufacture of PEX pipe, at the average annual bank rate established by the Bank of Canada at the minimum rate at which it makes short term advances to the banks listed in listed in Schedule 1 of the *Bank Act*, SC 1991, c 46.

[308] Post-judgment interest, not compounded, follows the establishment of the quantum of damages at the rate of five percent (5%) established by the *Interest Act*, RSC 1985, c. I-15, s 4.

I will reserve on any judgement regarding costs and request that the parties, within two weeks from delivery of these Reasons, provide written submissions as to costs, addressing matters set out in Rule 400(3) of this Court, including experts, number of counsel, disbursements, any offer to settle and any other matter relevant to an award of costs. Those submissions should not exceed ten (10) pages.

JUDGMENT

THIS COURT'S JUDGMENT is that

1. Claims 1, 2, 3, 4, 7, 8, 9, 11, 12, 13, 14, 15, 19, 22, 23, 24, 29, 30, 32, 33, 34, 35, 36, 37, and 38 of the '376 Patent are invalid;
2. Claims 16, 17, 25, 26, and 27 of the '376 Patent are valid and infringed by Pexcor and Heatlink;
3. Crosslink has not infringed any claims of the '376 Patent, either directly or indirectly;
4. Pexcor and Heatlink (and any subsidiary and affiliated companies, franchisees, officers, directors, employees, agents, licensees, successors, assigns and any other over whom they have control) are enjoined from manufacturing, using, offering for sale and/or selling to others for their use the apparatus for heating polymer material that infringes the '376 Patent and the PEX pipe made therefrom until expiry of the '376 Patent;
5. The Plaintiff is entitled to damages as a result of Pexcor and Heatlink's infringement of claims 16, 17, 25, 26, and 27 of the '376 Patent, the quantum of which is to be determined pursuant to the terms of the bifurcation Order issued on August 4, 2015;
6. The Plaintiff is not entitled to an accounting of profits;
7. The Plaintiff is entitled to pre-judgment interest on the award of damages, not compounded, at a rate to be calculated separately for each year since the infringing activity began, defined as the date of Pexcor's first commercially successful manufacture of PEX pipe, at the average annual bank rate established by the Bank of Canada as the minimum rate at which it makes short-term advances to the banks listed in Schedule 1 of the *Bank Act*, SC 1991, c 46;

8. The Plaintiff is entitled to post-judgment interest, not compounded, following the establishment of the quantum of damages at the rate of five percent (5%) established by the *Interest Act*, RSC 1985, c. I-15, s 4;
9. The Plaintiff is entitled to costs: the parties are to submit within two weeks from delivery of these Reasons written submissions as to costs, not exceeding ten (10) pages.

"Michael D. Manson"

Judge

FEDERAL COURT

SOLICITORS OF RECORD

DOCKET: T-496-11

STYLE OF CAUSE: UPONOR AB v HEATLINK GROUP INC. ET AL

PLACE OF HEARING: CALGARY, ALBERTA

DATE OF HEARING: JANUARY 11-21, 2016

JUDGMENT AND REASONS: MANSON J.

DATED: MARCH 16, 2016

APPEARANCES:

Mr. David Aylen
Ms. Heather Devine
Ms. Selena Kim
Ms. Charlotte McDonald
Ms. Natalie Rizkalla-Kamel

FOR THE PLAINTIFF

Mr. David Reive
Ms. Karen Phung

FOR THE DEFENDANTS,
HEATLINK GROUP INC. AND PEXCOR

Mr. James Swanson

FOR THE DEFENDANT
CROSSLINK FINLAND OY

SOLICITORS OF RECORD:

GOWLING LAFLEUR
HENDERSON LLP
Hamilton, Ontario

FOR THE PLAINTIFF

MILLER THOMSON LLP
Toronto, Ontario

FOR THE DEFENDANTS,
HEATLINK GROUP INC. AND PEXCOR

BURNET, DUCKWORTH &
PALMER LLP
Calgary, Alberta

FOR THE DEFENDANT,
CROSSLINK FINLAND OY

DIMOCK STRATTON LLP
Toronto, Ontario

FOR THE DEFENDANTS,
INOEX GMBH AND INOEX LLC